

Root Weld Formation in Modified Refractory Flux One-Sided Welding: Part 1 — Effect of Welding Variables

A portable, light, and efficient backing system with thermosetting flux offers solid support for root weld formation in field erection

BY V. MALIN

ABSTRACT. Experiments were conducted using modified refractory flux (MRF) welding developed in this program for field application. The effects of welding variables (current, voltage, travel speed, angle of electrode inclination, and amount of iron powder in the groove) on formation of root (backside) welds, including the root bead (deposit inside the groove) and the root reinforcement (deposit outside the groove) were studied. MRF welding is a new, portable, one-sided welding method that utilizes the submerged arc welding process (SAW), thermosetting backing flux, and direct current electrode negative polarity, and features a new, specially designed portable backing system. Modified refractory flux welding produces uniform root welds consistently in steel plate thicknesses ranging from 7.9 to 25.4 mm. It is intended for ship construction where constant welding conditions and groove geometry (especially a 1.6-mm maximum root opening) required for one-sided welding cannot be accurately maintained. The formation of root welds in MRF welding was studied in 17.5-mm-thick, single-V-groove butt joints with a wide (6.4 mm) root opening typical for erection joints. It was found when the root beads had a specific shape, it related to the development of defects in the following fill weld. Also, it was found that welding variables produced profound, and sometimes conflicting, effects on the root weld's shape. For example, increasing the current increased the deposition rate and the depth of joint penetration; however, root bead shape deteriorated and slag pockets formed, which may provoke defects in the following fill weld.

V. MALIN is with Malin's Welding Consultants, Inc., Highland Park, Ill.

Introduction

Refractory flux (RF) one-sided welding has long been successfully used in Japan (Ref. 1). Nevertheless, there is little known about the RF method in the United States. The distinguishable feature of the RF method is the application of special "thermosetting" (TS) backing fluxes (Ref. 2). Thermosetting flux in powder form is contained in a long trough that is applied to the backside of the plates to be welded, similar to the conventional SAW flux-backing (FB) method. Thermosetting flux contains a small amount of thermosetting resin. During welding, the resin is heated and hardens in front of the arc, turning the backing flux into a solid support for the molten weld pool. As a result, an acceptable root reinforcement is formed, and there is no need to turn the weldment over and gouge the root weld (as in the conventional SAW FB method). To increase productivity, two electrodes are used simultaneously to complete the weld in one pass, one following the other in a tandem arrangement. The leading arc is fed by direct current electrode negative (DCEN) polarity and forms a root

weld. The trailing arc operates on alternating current (AC) and fills the groove.

Producing an acceptable root weld is the most difficult task and the key to success in any one-sided welding method, including the RF method. If an acceptable root weld is formed, the rest of the groove may be filled in one pass using one or more additional electrodes and the same or different SAW technique, depending on plate thickness.

The RF method was designed primarily for shop applications. A shop provides favorable conditions, namely sufficient space for large, bulky backing systems and precisely prepared joints characterized by straightness, tight groove tolerances and narrow root openings (1.6 mm max). The RF method provides a good formation of the root weld if both welding variables and groove geometry can be kept fairly constant.

However, the RF method did not find wide application in the field, specifically at the erection stage of ship construction. The reason is that a typical field application is characterized by loose joint tolerances, including large root openings, wide variations in included angle, and significant plate misalignment caused by distortion of previously welded components. Loose joint tolerances present serious difficulties in obtaining adequate root welds. Another reason is imperfection of the backing systems. For field application, a backing system should be portable, light, and efficient. It should tolerate inaccurate joint preparation, intense heat, and adverse flux exposure. Also, very little data exists to establish relationships between root weld formation and varying welding variables or abnormal joint geometry.

Modified refractory flux (MRF) welding is a new, portable, one-sided method developed under the National Shipbuild-

KEY WORDS

One-Sided Welding
Submerged Arc Welding
DCEN
Field Application
Thermosetting Backing
Flux
Welding Variables
Root Weld Geometry
Iron Powder

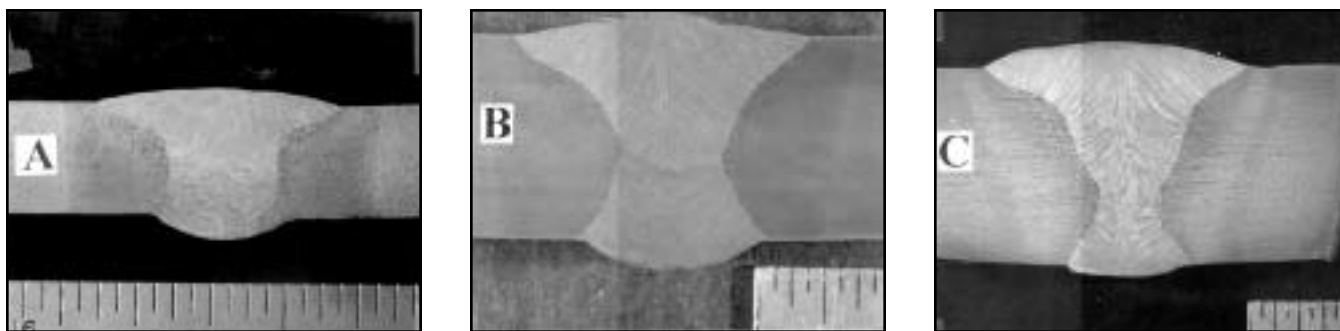

Fig. 1 — Welds completed by one-pass, two-electrode, one-sided MRF welding in plates of various thicknesses (T) assembled with large root openings (RO). A — $T = 9.5$ mm and $RO = 4.8$ mm; B — $T = 17.5$ mm and $RO = 6.4$ mm; C — $T = 25.4$ mm and $RO = 6.4$ mm. (Scale: 1 division = $\frac{1}{16}$ in. = 1.6 mm).

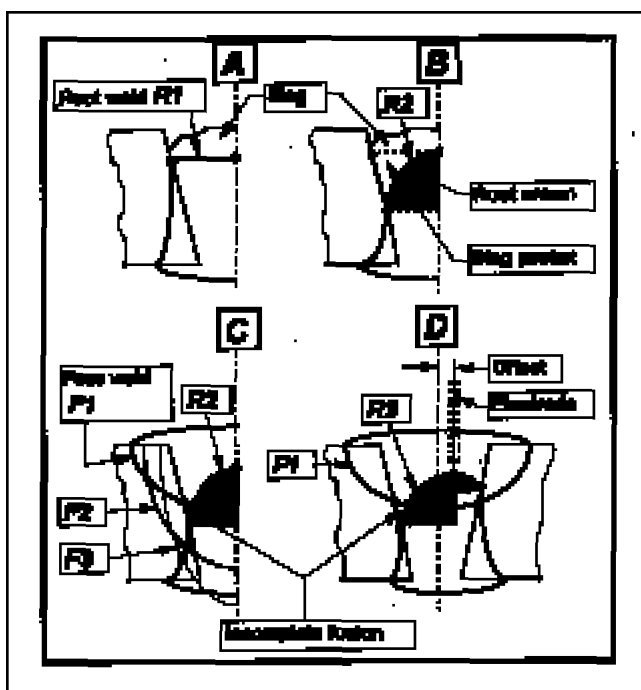

Fig. 2 — Relationships between the shape of the root bead and defect formation. A — Desirable (flat) shape of the root bead; B — undesirable crowned shape of the root bead and the resulting slag pockets; C — incomplete fusion in the fill weld due to slag pockets; D — slag pocket developed due to offset of the electrode.

ing Research Program. The MRF method consistently obtained uniform root welds under simulated conditions found at the erection stage of ship construction, characterized by wide variations in welding variables and joint geometry. The current laboratory experiments show adequate completed welds can also be produced in the flat position for single-V-groove butt joints in plate thicknesses ranging from 7.9 to 25.4 mm and wide root openings up to 9.5 mm as illustrated in Fig. 1A–C. Although the first implementation of the MRF method was reported to be successful (Ref. 3), further research is needed to provide wider practical appli-

cation of this promising method to field fabrication of ships, bridges, cranes, and other heavy steel structures where one-sided welding is beneficial.

The MRF method is similar to the original RF method. However, it features a new portable backing system specially designed for field application, which differs a great deal from the favorable shop environment where uniform and narrow root openings can be maintained. In contrast, much wider openings typically encountered in the field may present serious difficulties in obtaining adequate root welds.

To simulate field conditions, experimental root welds were obtained, using only the leading electrode, in joints with a wide (6.4 mm) root opening. Welding variables (current, voltage, travel speed, angle of electrode inclination, and amount of iron powder in the groove) were widely varied to understand the specifics of root weld formation at wide root openings.

The results of the experiments showed welding variables and groove geometry produced profound, and sometimes conflicting, effects on the shape of the root weld, particularly the root bead (deposit inside the groove) and the root reinforcement (deposit outside the groove). It was found also that the shape of the root bead

is crucial for the integrity of an entire weld because it may be related to development of incomplete fusion in the following fill weld. This behavior can be explained as follows.

In a two-electrode, one-pass MRF welding method, the leading electrode is followed by a trailing electrode at some distance. They deposit the root and fill welds at the same time. When the entire weld is completed, the shape of the root bead is not seen in all details because its face is fully remelted by the following weld. However, it is the shape of the root bead that may determine whether the fill weld develops internal defects, as is schematically illustrated in Fig. 2. Under optimal welding conditions, a desirable root weld shape can be obtained. It has a fairly flat top, as shown for root weld R1 in Fig. 2A. However, in reality, the root weld may not be flat. It may have an undesirable buildup or crown, as in root weld R2 shown in Fig. 2B. A crowned root weld may create deep pockets filled with slag on both sides of the groove. If fill weld F1 is deposited over root weld R2, as shown in Fig. 2C, it may not reach the bottom of the slag pockets creating incomplete fusion on both sides of the groove. To avoid these discontinuities, the fill weld must penetrate deeper as shown for weld F2 — Fig. 2C. In fact, penetration should be much deeper than would be necessary for a flat root weld. In this case, there is a risk that the fill weld may melt through the entire root weld (like weld F3 in Fig. 2C) and impair the appearance of the root reinforcement. A slag pocket may develop in the root weld on one side of the groove due to arc blow even if welding conditions are optimal and produce a flat root weld. It also happens if the electrode is offset about the center of the groove, as shown for root weld R3 in Fig. 2D. Due to some other reasons (to be discussed later), a slag pocket on one side of the groove may be deeper than that on the other side. In this

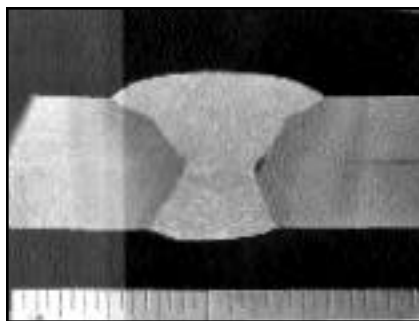

Fig. 3 — Incomplete fusion in the fill weld due to a slag pocket on one side of the root bead.

Table 1 — Basic Welding Conditions Used for Root Welds in MRF Welding

Plate thickness T	(mm)	17.5
Joint type		single-V butt
Included angle	(deg)	30 ± 5
Root opening RO	(mm)	6.4 ± 0.4
Root face RF	(mm)	0
Misalignment MA	(mm)	0
Electrode polarity (leading ^(a))		DCEN
diameter	(mm)	4.0
inclination	(deg)	15 (drag)
extension	(mm)	41 ± 3
Backing flux type		thermoset
Iron powder height f	(mm)	11.1 ± 0.5
volume $IR^{(b)}$	(%)	50 ± 5
Current I	(A)	600 ± 50
Voltage U	(V)	23.5 ± 0.5
Travel speed V	(cm/min)	39.6 ± 2.5

(a) Experiments were conducted using the leading electrode only. Trailing electrode (if used) operated on AC in tandem with the leading electrode.

(b) $IR = F_f/F_g \times 100\%$, where F_f is a cross section of the groove filled with iron powder and F_g is a cross section of the groove.

case, incomplete fusion in the fill weld may develop on that side of the groove where the slag pocket is deeper, as illustrated in Fig. 3.

The examples described above show the importance of understanding how variations of welding conditions and joint geometry may affect root weld formation in MRF welding. Due to the complexity of this research, the results are presented in two parts. Part 1 of this investigation describes the effect of welding variables on the shape of the root weld, groove geometry being constant. Part 2 describes the effect of joint geometry (the root opening, included angle, root face, and plate misalignment) on the shape of the root weld, the welding variables being constant. The effects of arc blow and tack welds are also discussed in Part 2.

Experimental Procedure

Equipment and Accessories

This investigation used a standard two-electrode tractor for SAW selected to

provide one-pass capability for plates up to 25.4 mm thick. The leading electrode was followed by the trailing electrode at a distance of about 127 mm in tandem, operating from DC and AC power sources, respectively. Only the leading arc was used during the experiments to deposit the root welds. The leading arc was direct current electrode negative (DCEN) polarity. Advantages of DCEN polarity (as applied to MRF welding) in comparison with direct current electrode positive (DCEP) polarity favored in conventional SAW are 1) higher deposition rate, which helps to deposit a thicker root weld; 2) lower penetration, which results in less risk of melting through a large root opening and damaging the MRF backing; and 3) arc stability at low voltage, which reduces arc blow and heat input.

The backing system was specially designed for multiple applications in MRF welding. It provides sufficient service life and competitive cost per foot of welding in comparison with popular consumable backing systems used currently in ship construction.

The MRF backing system consists of portable 610-mm-long backup units assembled along and under the joint to be welded. The backup unit holds a thin layer of powder thermosetting flux. Special mechanical and magnetic devices allow this flux to be applied to the back side of the joint under uniform pressure to provide a fairly even density.

The backing flux contains a small

amount of phenolic thermosetting resin. During welding, the powder thermosetting flux in front of the arc is heated by arc radiation and heat conduction through the welded plates. The resin hardens and turns a thin layer of the flux into a solid briquette. The briquette develops maximum compressive strength and heat resistance at 150–200°C and prevents the weld metal from melting through the flux as occurs in the conventional SAW FB method. If the thermosetting flux is heated to lower temperatures, the strength and heat resistance of the briquette are not sufficient and the molten metal may melt through the flux (a melt through condition). Some melting of the briquette surface always occurs under the weld pool under normal conditions, with maximum melting being in the center of the pool. This assists in creating a root reinforcement. A thin layer of molten slag covers and protects the weld pool from the atmosphere. Also, the slag contains deoxidizers and iron powder. As a result of the interaction between the molten slag and metal, the surface of the root reinforcement has a very smooth, silvery, and shiny appearance. It blends into the base metal very well.

Materials Welding Conditions and Specimen Preparation

Two steel plates (17.5 x 305 x 1219 mm) were oxyfuel cut and beveled at

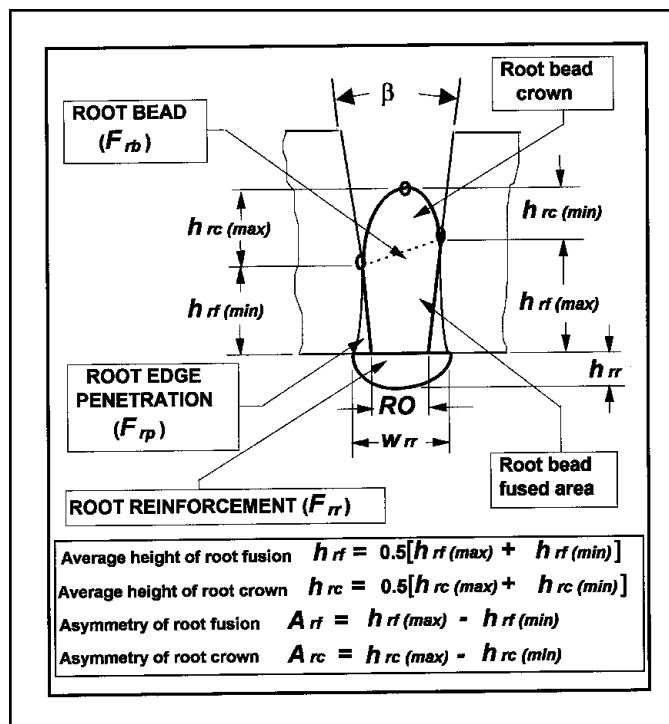

Fig. 4 — Characteristic areas and dimensions of the root bead.

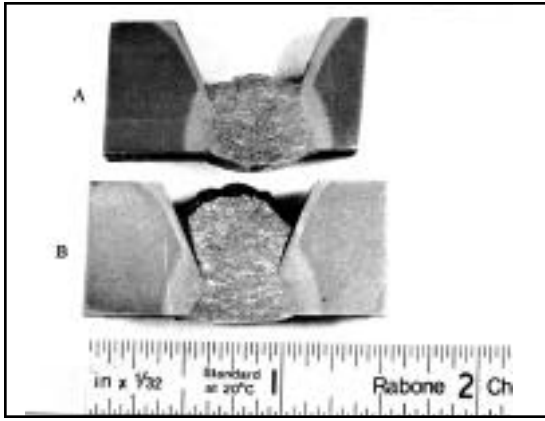

Fig. 5 — Cross sections of the root beads deposited at different currents. A — $I = 600$ A; B — $I = 1000$ A.

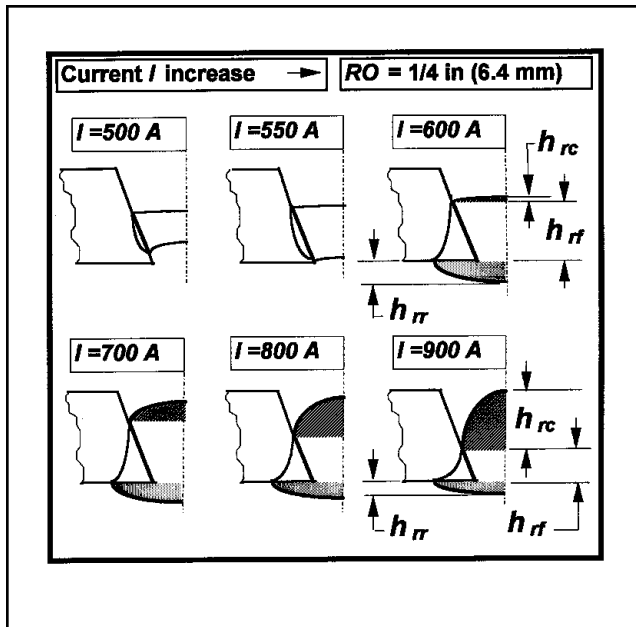

Fig. 6 — Relationships between the shape of the root bead and the current.

22.5 or 15 deg and assembled to form a single-V-groove butt joint. The root weld was deposited using the lead electrode only, changing one variable at a time, which included current (I), voltage (U), travel speed (V), angle of inclination of the electrode (θ), and height of iron powder (f). Groove geometry was maintained constant with root opening $RO = 6.4$ mm, included angle $\beta = 45$ or 30 deg, root face $RF = 0$, and plate misalignment $MA = 0$. Basic welding conditions are given in Table 1, unless specified otherwise. Numerous transverse specimens were cut from each weldment. The cross section of each specimen was polished and etched to reveal a weld profile. The profile was reproduced and enlarged. To quantitatively characterize and compare

verse specimens of the root weld, which weren't always symmetrical — Fig. 4.

Results and Discussion

Effect of Current

Welding current produces a complex, and sometimes conflicting, effect on root weld geometry largely through its effect on deposition rate and arc penetration. Since current has a different effect on the root bead and root reinforcement, that will be discussed separately.

Effect of Current on Shape of Root Bead

The shape of the root bead can be quantitatively characterized by the root

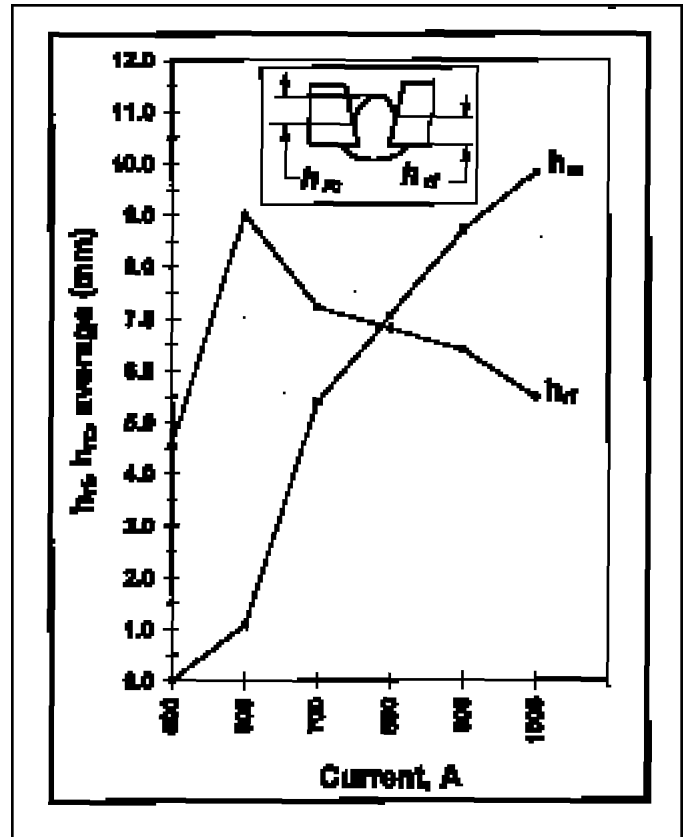

Fig. 7 — Effect of current on fusion characteristics of the root bead. h_{rf} = height of root fusion; h_{rc} = height of the root crown (slag pocket).

the shape of different root welds, its geometry was defined as a combination of characteristic dimensions and cross-sectional areas determined by measuring the enlarged reproductions taken from the trans-

verse specimens of the root weld, which weren't always symmetrical — Fig. 4. The most important are height of root fusion h_{rf} and height of root crown (height of slag pockets) h_{rc} .

Analysis of Root Bead Cross Sections

A number of samples were obtained from the welds performed at currents varying from 500 to 1000 A. Other welding conditions are given in Table 1.

Analysis of the weld cross sections showed the shape of the root bead changed dramatically as the current increased. For example, compare the cross sections of two root welds made at 600 and 1000 A, respectively, as shown in Fig. 5A and B. The transformation of the root weld shape is schematically illustrated in Fig. 6. The most noticeable and largely unfavorable effect is produced on root fusion and the root crown (accentuated by heavy lines and cross-hatched areas, respectively). The size of the root reinforcement is affected to a lesser degree.

At 500 A, root fusion (heavy line) did not reach the bottom of the groove — Fig. 6. At 550 A, root fusion was improved,

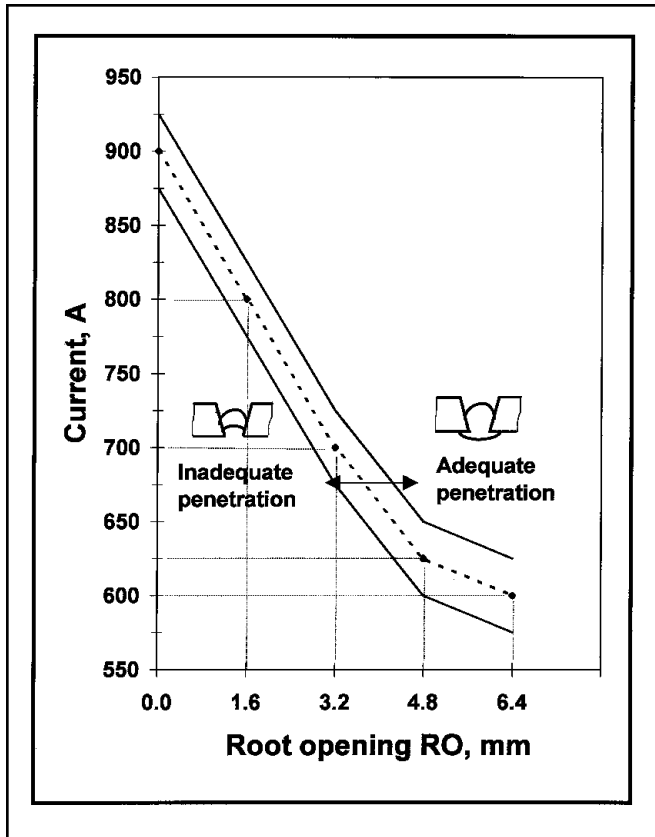

Fig. 8 — The current required for adequate root edge penetration at various root openings.

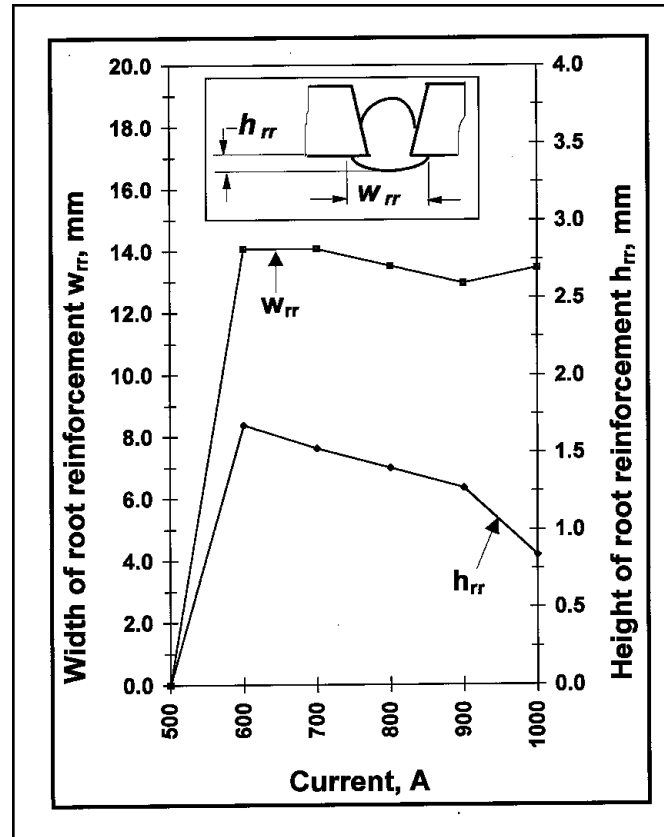

Fig. 9 — Effect of current on geometry of the root reinforcement. h_{rr} = height of the root reinforcement; w_{rr} = width of the root.

but no (or inadequate) root reinforcement developed. At 600 A, the arc eventually broke through the root edges and developed a full-sized root reinforcement. The top of the root bead looked fairly flat and no (or negligible) root crown developed. At 700 A, the root fusion decreased and a noticeable crown appeared (cross-hatched area). At 800 and 900 A, root fusion progressively deteriorated and the crown became increasingly taller. It formed deep (and sometimes sharp) pockets filled with slag.

Effect of Current on Fusion Characteristic of Root Bead

The effect is quantitatively illustrated in Fig. 7. At 600 A, the height of root fusion was the highest, h_{rf} = 9.1 mm or 52% of the plate thickness (52% T). As the current increased from 600 to 1000 A, h_{rf} dropped from 9.1 to 5.5 mm (31% T). This behavior represents almost 40% reduction in root fusion. At the same time, the height of the root crown (height of the resulting slag pockets) h_{rc} increased dramatically, from 1.1 to 9.8 mm (from 6% T to 56% T). Such a shaped root bead is detrimental because it may cause internal defects in the following fill weld, as

discussed earlier.

It was obvious that, at 600 A (and other conditions described in Table 1), the shape of the root bead was most favorable because h_{rf} was the maximum, while h_{rc} was almost zero. Such current is called the critical current (I_{cr}). As the current increased above I_{cr} , the fusion characteristics of the root bead deteriorated, namely h_{rf} decreased and h_{rc} grew taller.

Effect of Current on Shape of Root Reinforcement

Normally, MRF welding provides a very smooth and shiny root reinforcement. It is uniform along the joint and blends into the base metal well, as shown in Figs. 1, 3, and 5.

Formation of Root Reinforcement

Root reinforcement is formed in two steps: 1) the liquid metal penetrates through the root edges and spills out, and 2) the liquid metal melts a groove in the hardened backing flux. The effects of the current on edge penetration and flux melting are rather complex.

Root edge penetration (F_{rp}) is where the molten metal penetrates through the

base metal F_{rp} — Fig. 4. It is surrounded by the heat-affected zone (HAZ) where the base metal is heated to A_{C1} temperature (approximately 750°C for steel). As the current increases, the depth of penetration and the depth of the HAZ gradually increase. At some current, the depth of HAZ reaches the bottom of the joint. According to Ref. 4, at this moment, the penetration sharply increased and the molten metal suddenly reached the bottom of the joint. This behavior was confirmed by the experiments in this investigation and illustrated in Fig. 6.

At 500 A, the current was not sufficient, the HAZ did not reach the bottom of the joint, and the weld metal remained inside the groove. At 550 A, the HAZ and the molten metal suddenly reached the bottom of the joint. At 600 A, the weld metal was forced out of the groove by arc forces and the gravity of molten metal, which are great in automatic SAW. This is the first stage of forming the root reinforcement, which is largely determined by the current.

However, if the current increases above 1000 A (in a joint with a wide root opening), F_{rp} could become so large most of the liquid metal would fall through the entire thickness of the backing flux. This

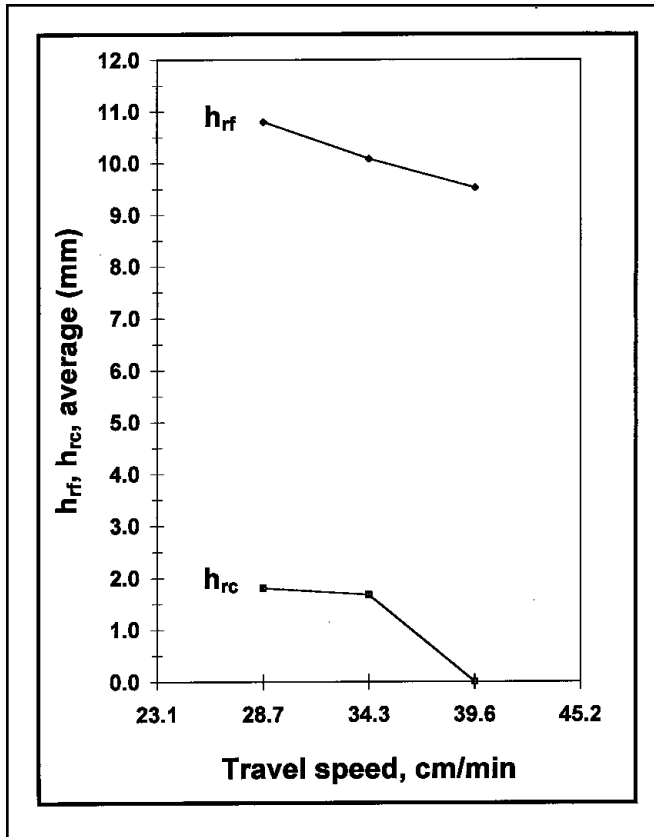

Fig. 10 — Effect of travel speed on fusion characteristics of the root bead. h_{rf} = height of root fusion; h_{rc} = height of the root crown (slag pocket).

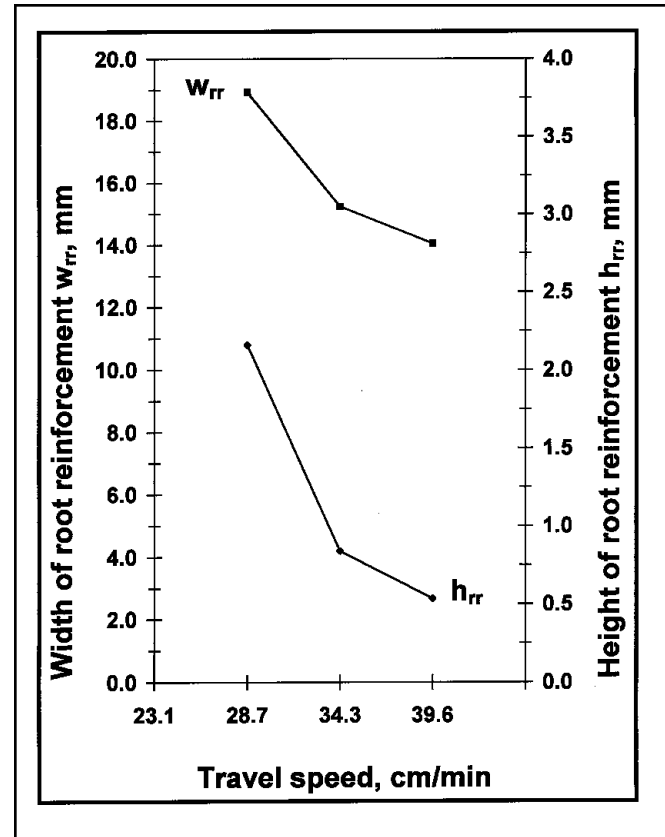

Fig. 11 — Effect of travel speed on geometry of the root reinforcement. h_{rr} = height of the root reinforcement; w_{rr} = width of the root reinforcement.

melt-through situation produced an excessively large and irregular root reinforcement.

F_{rp} depends on other variables and joint geometry. At equal current, root edge penetration may be reduced by placing iron powder into the groove, decreasing the root opening or the included angle, or increasing the root face. For example, the effect of the root opening is illustrated in Fig. 8 (based on welding conditions described in Table 1). The dashed line indicates the recommended minimum current required to adequately penetrate through the edges of the V-groove at various root openings. The area within a narrow (± 25 A) band is a scatter of data. The areas above and below the band are the areas of adequate and inadequate root edge penetration, respectively. It is evident the wider the root opening, the lower the current needed for adequate root edge penetration, and vice versa. For example, at 550 A, root edge penetration is not sufficient for a root opening of 6.4 mm because 600 A is required. However, at RO = 3.2 mm, 700 A is required rather than 600 A.

Melting a groove in the backing flux is the second step in the process of forming the root reinforcement. In the MRF

method, this process differs from that of other one-sided welding methods. For example, the flux-backing (FB) welding method utilizes powder backing fluxes (commonly used for SAW) to support the molten weld (Ref. 5). As the current or flux density changes, so does the height of the root reinforcement (h_{rr}), which is not uniform and poorly predictable (Ref. 4). On the other hand, the copper backing (CB) or copper-flux backing (CFB) welding method utilizes a copper bar to support the molten metal (Refs. 6, 7). In this case, h_{rr} does not depend on the current. It is uniform and predictable (Refs. 8, 9).

MRF one-sided welding can be viewed as a combination of FB and CB methods. It may be classified as the FB method because the backing flux is initially in a powder state. However, it hardens in front of the arc and the weld pool is formed on a solid support as in the CB method. As a result, the effect of the current is mixed. h_{rr} is rather uniform as in the CB method, but depends on the current as in the FB method.

In the MRF method, the height and the width of the root reinforcement are determined by the height and width of the groove gouged by the molten metal in the

hardened backing flux due to melting of iron powder and other ingredients of the flux. The mechanism of root reinforcement formation in the MRF method is rather complex because it is associated with metal-slag heat transfer due to radiation and conductivity, balances of forces of gravity and arc pressure, surface tension of molten metal, and slag, etc.

Effect of Current on Height and Width of Root Reinforcement

The effect of current is illustrated schematically in Fig. 6 and quantitatively in Fig. 9 (based on conditions in Table 1).

The effect of the current on height of the root reinforcement h_{rr} is complex. At $I < I_{cr}$ (600 A), the arc did not penetrate deep enough and no (or inadequate) root reinforcement was formed. At $I = I_{cr}$, the arc broke through the root edges and a full-height root reinforcement developed. In fact, the maximum $h_{rr} = 1.7$ mm was achieved at I_{cr} . Then, h_{rr} decreased as the current increased above I_{cr} . For example, at 1000 A, $h_{rr} = 0.8$ mm (drop by about 60%). Such a trend is not favorable because a low-profile root reinforcement is inherent in MRF welding and an increase of h_{rr} is desirable. The minimum

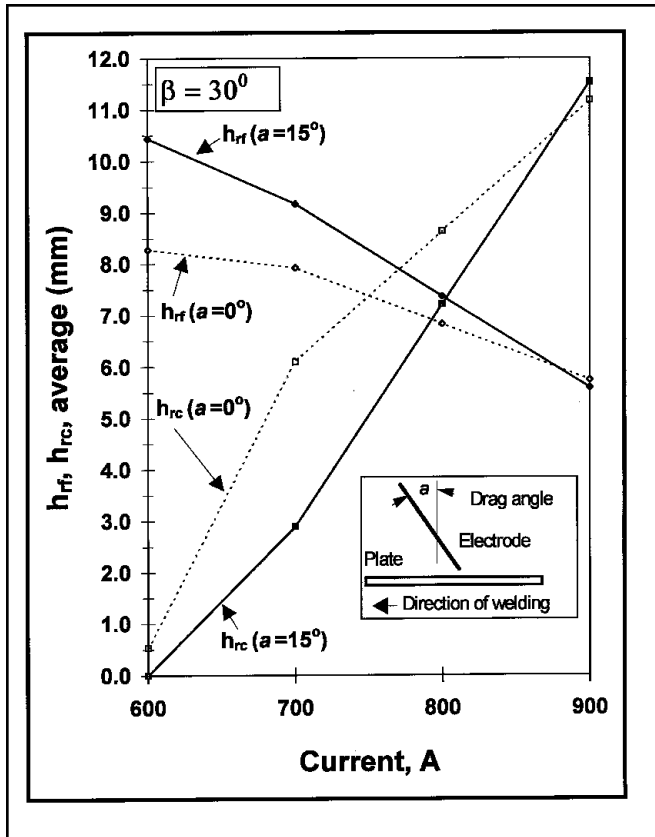

Fig. 12 — Effect of electrode inclination () on fusion characteristics of the root bead. h_{rf} = height of root fusion; h_{rc} = height of the root crown (slag pocket).

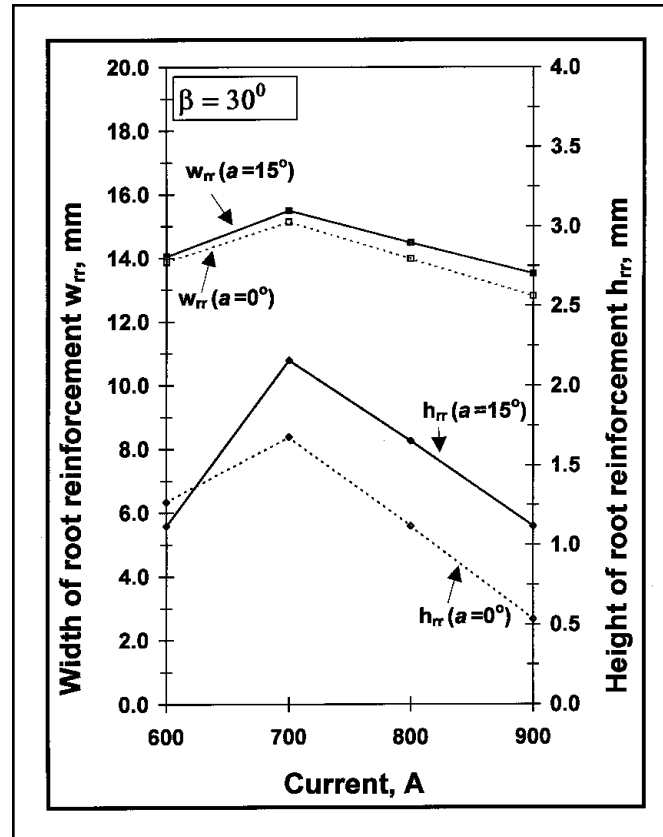

Fig. 13 — Effect of electrode inclination () on geometry of the root reinforcement. h_{rr} = height of the root reinforcement; w_{rr} = width of the root reinforcement.

(acceptable in this program) was $h_{rr \min} = 0.8$ mm. According to Fig. 9, $h_{rr} > h_{rr \min}$ was achieved over the entire range of 600 to 1000 A.

The effect of current on the width of root reinforcement w_{rr} is shown in Fig. 9. At $I < I_{cr}$ (600 A), no (or inadequate) root reinforcement was formed. At $I = I_{cr}$ (600 A), the arc broke through the root edges and a full-width root reinforcement developed (w_{rr} 14.1 mm). As the current increased from 600 to 1000 A, w_{rr} was practically independent of current and varied very little (within 14.1 – 13.0 mm).

Criteria for Selection of Current

The criteria for selection of current for the root weld in MRF welding differs from other one-sided welding methods. In MRF welding, the requirements should be met for both root bead and root reinforcement as follows:

- 1) Minimal height of the root crown/slag pockets ($h_{rc} = \min$)
- 2) Maximum possible height of root fusion ($h_{rf} = \max$)
- 3) Maximum possible cross-section area of the root bead ($F_{rb} = \max$)
- 4) Minimal asymmetry of root fusion ($A_{rf} = \min$)⁽¹⁾

5) Maximum possible root edge penetration ($F_{rp} = \max$)

6) Maximum possible size of the root reinforcement ($h_{rr} = \max$ and $w_{rr} = \max$).

It is difficult to find an ideal current to satisfy all requirements for both root bead and root reinforcement under the explored range of welding conditions. The same is true under versatile conditions encountered in production. In this respect, an optimal current may be considered for the root weld that may not satisfy all criteria. This is acceptable if the optimal current is in consideration of the method and welding conditions selected for the fill weld following the root weld. In fact, the fill weld should minimize negative effects and maximize positive effects produced by the optimal current on root weld geometry. Below are some examples.

1) Under the explored conditions (two electrodes arranged in tandem, welding conditions per Table 1, RO = 6.4 mm), the critical current may be considered as an optimal current. However, it may not fully satisfy criterion 3 above because the root weld cross section may not be sufficient. In fact, the remaining (not filled) cross section of the groove (F_{rb}) is quickly filled with the following weld. F_{rb} deter-

mines the required current for the fill weld. The larger the F_{rb} , the higher the deposition rate and the current required for the fill weld. If F_{rb} is too large, the required current may be too high and the arc may melt through the entire root weld impairing root reinforcement. This can be overcome if the remaining groove is filled in more than one pass. For 17.5-mm-thick plates, a three-electrode arrangement may be a solution.

2) In production, the root opening may vary from 3.2 to 6.4 mm. If I_{cr} is used as an optimal current, then it will not satisfy criteria 1, 3, 5, and 6. However, some of these drawbacks can be overcome if 700 A is considered as an optimal current. In this case, criteria 3, 5, and 6 will be satisfied. Also, the negative effect of criterion 1 will be neutralized if the slag pockets developed on both sidewalls of the groove (as a result of increasing the current) are remelted by the fill weld. For this purpose, a twin-electrode arrangement may be a better solution than that in example 1. (A twin-electrode arrange-

1. Deep slag pockets on one or another side of the groove (asymmetrical root bead) may develop as a result of arc blow, which strengthens as DC current increases (Ref. 10).

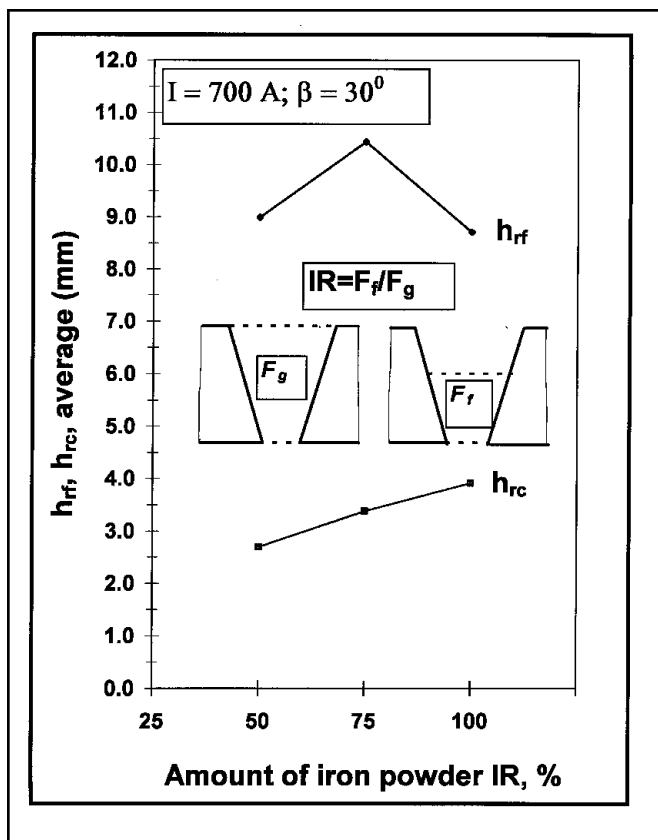

Fig. 14 — Effect of iron powder on fusion characteristics of the root bead. F_r = groove cross section occupied by iron powder; F_g = groove cross section; h_{rf} = height of root fusion; h_{rc} = height of the root crown (slag pocket).

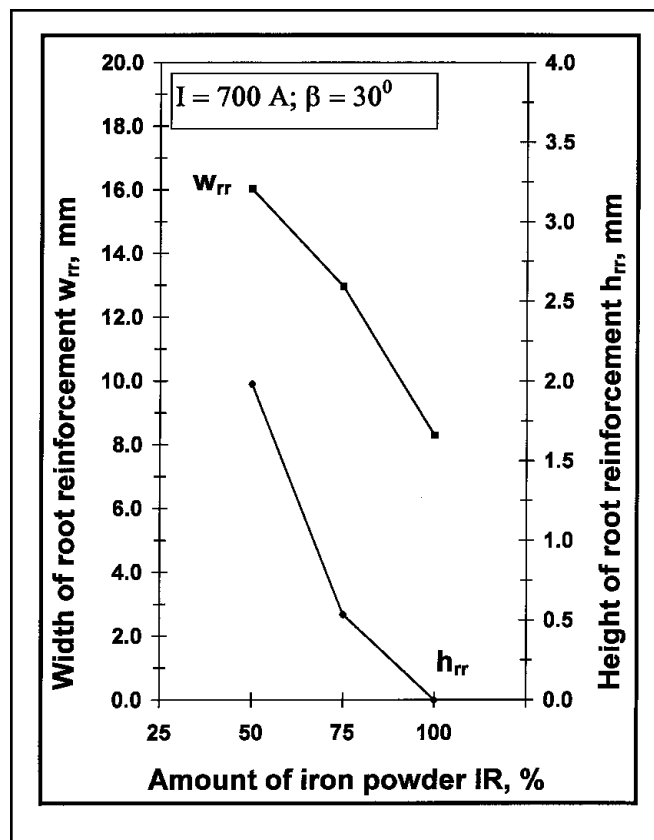

Fig. 15 — Effect of iron powder on geometry of the root reinforcement. h_{rr} = height of the root reinforcement; w_{rr} = width of the root reinforcement.

ment has two electrodes fed in parallel from a single power source and arranged across the groove).

Effect of Voltage

Effect of voltage was studied by varying it from 20 to 30 V. Acceptable root welds were obtained within the range of 23–25 V. At $U < 22 \text{ V}$, the arc became unstable resulting in an unacceptable root weld reinforcement. At $U > 26 \text{ V}$, the arc became longer and more sensitive to arc blow. The arc jumped from one side of the groove to another. As a result, voltage and current became erratic. The backing flux did not receive enough heat through radiation and did not harden fast enough in front of the arc. The molten metal melted through the entire flux layer resulting in unacceptable formation of the root reinforcement, frequent melt-through, and damage to the backup unit. Thus, invalid data were obtained beyond the acceptable range because the dimensions of the root bead, or reinforcement, could not be measured or fluctuated erratically.

In contrast to conventional SAW oper-

ating at DCEN polarity and other one-sided welding methods, much lower voltage (short arc length) is required for the MRF welding method. Therefore, the voltage was maintained in a very narrow operating range of 23–25 V for all welds tried in this program. Low voltage helps reduce arc blow and heat input to avoid damage to the backing system.

The results of this investigation, although qualitative rather than quantitative, show the MRF method is very sensitive to voltage but is not controlled by this welding process parameter. However, this does not mean the voltage is not an important or essential variable. To obtain acceptable root welds, the voltage is the second most important process parameter after current.

Effect of Travel Speed

In any welding method, travel speed is known to control two important factors: the rate of deposited weld metal and heat input. The lower the travel speed, the greater are both factors. In the two-electrode, one-pass technique used in these experiments, it was important to

deposit balanced amounts of metal for the root and the fill welds. However, control over the amount of deposited metal is limited by consideration to provide a favorable shape to the root weld (the bead and reinforcement), which is controlled by the current. Therefore, the effect of the travel speed on the shape of the root weld should be considered in relationship to the current (for a given plate thickness T). On the other hand, a decrease in travel speed increases heat input not only for the root weld, but also for the fill weld. That is why travel speed should be considered with caution in developing MRF welding procedures, especially for heat-sensitive steels.

Effect of Travel Speed on Shape of Root Welds at $I = I_{cr}$

As discussed previously, the critical current I_{cr} produced a favorably shaped root bead. In fact, it was produced at a certain critical travel speed (V_{cr}). The critical travel speed is the maximum possible speed at which a favorably shaped root weld is still produced. For example, at 600 A and with the welding conditions

likely to occur along the same joint in production. Therefore, no adjustments in iron powder height was made during the experiments to compensate for root opening or included angle. For example, for $f = 11.1$ mm, IR was considered to be equal to 50% in all 17.5-mm-thick joints explored in this program.

Effect of Shape of Root Bead and Reinforcement

Experiments were conducted to determine the effect of iron powder on the shape of the root bead and root reinforcement. Root welds were made at 700 A in a root opening of 6.4 mm with varying amounts of iron powder in the groove. Other welding conditions are given in Table 1, except that $\beta = 30$ deg. The thicknesses of iron powder were $f = 6.4$ mm (IR = 25%), $f = 11.1$ mm (IR = 50%), $f = 14.3$ mm (IR = 75%), and $f = 17.5$ mm (IR = 100%, full thickness of the plate).

The effects of iron powder on the fusion characteristics of the root bead is illustrated in Fig. 14. At IR = 25% and a root opening of 6.4 mm, iron powder does not protect the joint from melt-through and most of the root bead metal falls under the plate (no data are shown on the graph). As IR increases from 50 to 75%, h_{rf} slightly increased (by 16%) and then decreased. However, the height of the root crown increases dramatically, at IR = 75% by 26% and at IR = 100% by 45%. Thus, the best combination of fusion characteristics is achieved at IR = 50% because h_{rf} is fairly high, while h_{rc} is at its smallest.

The effect of iron powder on the shape of the root reinforcement is illustrated in Fig. 15. At IR = 25%, unacceptable root reinforcement is obtained due to melt-through. As IR increases from 50 to 100%, both the height and width of the root reinforcement decrease drastically. For example, at IR = 100%, h_{tr} drops to zero, that is, no reinforcement develops. Thus, the best shape of the root reinforcement is achieved at IR = 50%.

Effect of Ir on Powder on Root Weld Shape at Other Welding Conditions

The effect of iron powder may be different from that described above if welding conditions differ from those in Table 1. At smaller RO and/or β (reduced root edge penetration), IR < 50% may be sufficient to avoid melt-through. In fact, at RO = 0, melt-through can be avoided even without iron powder. On the other hand, IR > 50% may be required under conditions that increase the root edge penetration. For example, acceptable

root reinforcements were obtained at RO = 6.4 mm and I = 900 A, even at IR = 100%.

Conclusions

The results of this study allow the following conclusions to be made:

1) Welding current produces the most favorable effect on root bead shape at a certain magnitude called critical current ($I_{cr} = 600$ A). At $I > I_{cr}$, the shape of the root bead deteriorated; namely, the height of root fusion h_{rf} decreased and the height of the root crown h_{rc} increased. As a result, the risk of internal defects increases. The most desirable size of the root reinforcement is at I_{cr} . As current increased, the height of the root reinforcement surprisingly decreased, while the width did not change much. Since low h_{tr} is inherent in the MRF method, such a trend is not favorable. Still, the size of the root reinforcement obtained in the current range of 600–1000 A is considered acceptable.

2) In contrast to conventional SAW and other one-sided welding methods, a very low and narrow operating range of 23–25 V is required for MRF welding. Beyond this range, acceptable root welds are difficult to obtain. The MRF method cannot be controlled by voltage. However, it is the second most important process parameter, after current, to obtain acceptable root welds.

3) The effect of travel speed V depends on the current. Favorable root fusion characteristics and shape of the root reinforcement are obtained at I_{cr} and at the critical speed $V_{cr} = 39.6$ cm/min. Moderate improvements are observed within a narrow speed range below V_{cr} as V decreases from 39.6 to 28.7 cm/min. However, these benefits are offset by a much higher increase in heat input and may result in deterioration of weld and HAZ metal properties in heat-sensitive steels.

4) The inclination (θ) of the leading electrode from the vertical in the direction of welding produced a significant and beneficial effect on the shape of the root weld. At $\theta = 15$ deg, root fusion characteristics improved in comparison to $\theta = 0$, most significantly at I = 600 A. As the current increased above I = 600 A, this effect was gradually reduced to zero at I = 900 A. The height and width of the root reinforcement increased also, most noticeably at I = 600 A.

5) Iron powder affects the root fusion characteristics and the shape of root reinforcement. The best results were obtained at I_{cr} and with the amount of iron powder in the groove (by volume) IR = 50%. Increasing IR above 50% led to deterioration of the root fusion characteris-

tics and the shape of the root reinforcement. At IR < 50%, there is a risk of melt-through.

Acknowledgments

The author gratefully acknowledges financial support for this work by National Shipbuilding Research Program. Thanks are also extended to National Shipbuilding and Steel Company (NASSCO) for materials and equipment provided for the experimental work

References

1. Terrai, K., and Arikawa, M. 1969. *Recent Developments in One-Side Automatic Welding*. The Sanpo, Inc., Tokyo, Japan.
2. Kobe Steel, Ltd. 1967. Procédè de soudage en bout sur une seule face. Frank. Brèvet d'invention. N 1496766, k1. B.23 k (French patent).
3. Sullivan, M. J. 2000. One side single pass SAW. *Proceedings: How to Competitively Weld the 21st Century Ship*, Norfolk, Virginia, 31s–51s.
4. Inagaki, M., and Okada, O. 1968. Fundamental research on one-side arc welding. *Transactions of National Research Institute for Metals*, Japan 10(2): 93s–103s.
5. Keir, J. M. 1939. Welding. U.S. Patent N 2145009, C1. 219–10.
6. Raevsky, G. V., and Rublevsky, I. N. 1949. One-side welding of butt joints using flux-copper backing. *Transactions of Paton Welding Institute on Automatic Submerged Welding*, No. 5, Kiev, USSR.
7. Arikawa, M., Okuda, N., and Kono, M. 1966. Electric arc working for welding one-side of two pieces of steel plates. U.S. Patent No. 3351734, cl. 219–137.
8. Japan Institute of Welding. 1969. A summary on the present status of one-side submerged arc welding in Japan. Tokyo, Doc. ITW-XII-471-69, American Council, AWS, Miami, Fla.
9. Miyazaki, T., et al. 1993. Development of high-speed FCuB (flux-copper backing) one-side submerged arc welding process. *Hitachi Zosen Technical Review*, 54(1): 71s–85s.
10. Cary, H. B. *Modern Welding Technology*. Third Edition, Regents/Prentice Hall, Englewood Cliffs, New Jersey, 664-s to 666-s.
11. Bailey, N. 1991. Submerged arc welding ferritic steels with alloyed metal powders. *Welding Journal* 70(8): 187-s to 205-s.