

# Selection of Schedules Based on Heat Balance in Resistance Spot Welding

*A theory that takes into account heat input in the fusion zone, HAZ, and electrode indentation was used to develop schedules for welding combinations of uneven sheet thicknesses*

BY S. AGASHE AND H. ZHANG

**ABSTRACT.** It is impossible to make a complete list of welding schedules in resistance spot welding because of the large number of possibilities of sheet combinations. Therefore, the welding parameters chosen for a particular welding operation are largely dependent on the experience of the operator, although some guidelines are available. The difficulty in schedule selection arises from the number of interdependent parameters involved, such as different sheet thickness combinations, different material properties of the sheets, welding current and welding time, electrode face diameter, electrode force, etc. There are a number of efforts attempting to develop systematic procedures for welding schedule selection, such as the law of thermal similarity, yet none of them has been widely accepted, primarily due to the fact that the schedules produced by these procedures are often proven inadequate.

In this study, a new method is proposed for selecting welding schedules based on the heat balance in welding. A theoretical derivation of welding parameters is conducted using a "characteristic" thickness, instead of the physical thickness of sheets. This thickness consists of the effects and contributions of electrode indentation, heat-affected zone, and fusion zone. The theory has been verified by welding low-carbon steel sheets of uneven thickness.

## Introduction

Resistance spot welding (RSW) is a major sheet metal joining process in many industries, such as the automotive, appliance, and aerospace industries. Resistance welding was invented by Elihu Thomson in 1877 (Ref. 1) and has grown enormously since the first steel welded automobile was introduced in 1933 (Ref. 1). Resistance spot welding has become the predominant means for auto body assembly, with an average of two to five thousand spots on each passenger car produced (Ref. 1).

S. AGASHE and H. ZHANG are with Mechanical, Industrial and Manufacturing Engineering, The University of Toledo, Toledo, Ohio.

In resistance spot welding, a primary concern for a practitioner is to select correct welding schedules. A welding schedule is a set of welding parameters, such as welding current, weld time, electrode force, and electrode face diameter, which would produce a weld with desired features, such as certain geometric dimensions, weld strength, etc. The Resistance Welder Manufacturers' Association (RWMA) (Ref. 2) offers weld schedules and many other recommended practices are available for this purpose. Most of the weld schedules are empirically developed. Although they are very useful in finding good weld schedules for even-thickness welding, schedules for welding uneven-thickness sheets are generally developed by and practiced within individual manufacturers. Because even-thickness combinations are rarely used in practice, there is clearly a practical need of welding schedules for uneven-thickness combinations. Both theoretical and combined theoretical-empirical methods have been employed for systematically determining welding schedules. The common techniques used in this respect are summarized below.

## The Law of Thermal Similarity

The law of thermal similarity (LOTS) has been commonly used in the automotive industry in Japan to develop resistance welding schedules (Ref. 3). It is based on a heat flow analysis, which attempts to make the temperature distributions in various weld thicknesses similar. The LOTS has been used to develop

schedules to obtain desirable temperature profiles based on the known data, i.e., to extrapolate the results obtained from known standard specimens for predicting the temperature profile for a different combination of sheet stack up (Ref. 4). It gives a relationship between the distance and time that makes the temperature distributions similar for different thickness stack ups. It has been mostly used as a guideline for choosing welding schedules for thick sheets based on those verified for thin sheets.

The law of thermal similarity states that similar temperature profiles will be produced if the weld time is proportional to the square of the sheet thickness (Ref. 4), or

$$t \propto h^2 \quad (1)$$

i.e., if the welding time is  $t_1$  for a sheet of thickness  $h_1$ , then  $n^2 t_1$  is the time needed to weld a sheet of thickness  $n \times h_1$ . The total weld time is determined by the total thickness of the stack up and the thinnest outer sheet determines the maximum duration of any weld pulse. Other welding parameters can be derived similarly.

In general, when the plate thickness and diameter of the electrodes are magnified by  $n$  times, the welding time should be increased to  $n^2$  times and the current density decreased to  $n$  times in order to have the new temperature distribution similar to the original one (Refs. 3, 5).

Let  $h_1$  ( $h_2$ ),  $de_1$  ( $de_2$ ),  $\delta_1$  ( $\delta_2$ ), and  $t_1$  ( $t_2$ ) be the thickness, electrode diameter, current density, and welding time, respectively, of the original sheet stack up (the new sheet stack up). Then, the temperature distributions for the two stack ups are similar if (Ref. 3)

$$h_2 = n \times h_1 \quad (2)$$

$$de_2 = n \times de_1 \quad (3)$$

$$\delta_2 = (1/n) \times \delta_1 \quad (4)$$

$$t_2 = n^2 \times t_1 \quad (5)$$

## KEY WORDS

Resistance Welding  
Weld Schedule  
Heat Balance  
Spot Welding  
Uneven Thickness  
Sheet Metal

**Table 1 — Welds Made with Different Schedules**

Sheet Thickness (mm)	Source of Weld Schedule	LOTS Factor n	Electrode Diameter (mm)	Welding Current (A)	Welding Time (ms/cycles)	Electrode Force (kg/lb)	Weld Diameter (mm)	Expulsion Occurrence	Surface Condition
0.75	Handbook (Ref. 6)		6.35	10500	150/9	227/500	6.10	No	Good
	LOTS from 1.21	0.62	4.41	8367	77/4.6	136/299	3.2	No	Good
	LOTS from 1.89	0.40	3.15	6547	45/2.68	93/204	2.89	No	Good
1.21	Handbook (Ref. 6)		7.11	13500	200/12	354/80	7.07	No	Good
	LOTS from 0.75	1.61	10.24	16940	390/23.43	590/1301	7.76	Very Heavy	Damaged
	LOTS from 1.89	0.64	5.08	10563	116/6.97	242/532	3.4	No	Good
1.89	Handbook (Ref. 6)		7.94	16500	283/17	590/1300	8.01	No	Good
	LOTS from 0.75	2.52	16.00	26460	953/57.15	1440/3175	11.3	Very Heavy	Damaged
	LOTS from 1.21	1.56	11.11	21086	488/29.28	863/1903	10.8	Very Heavy	Damaged

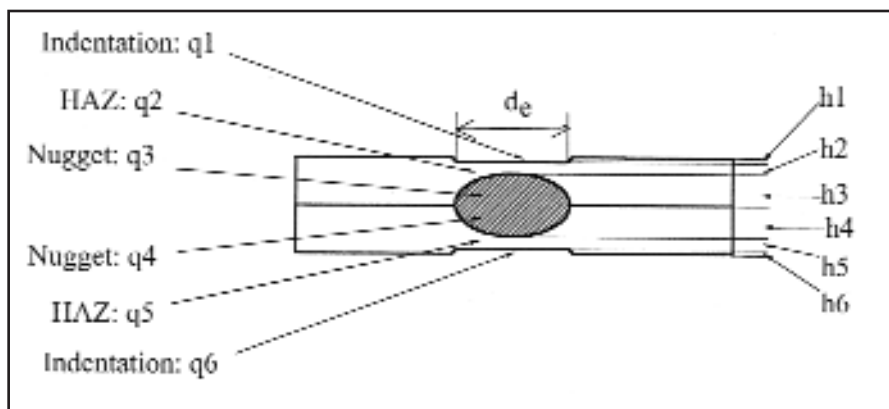

Fig. 1 — Partition of zones in a weldment for heat calculation.  $q$  = heat (Joules),  $h$  = thickness (mm).

### Limitations of the Law of Thermal Similarity

Although the law of thermal similarity may theoretically yield similar temperature profiles for different stack ups, many of the welds obtained by the authors using the LOTS schedules were either undersized or with heavy expulsion. As the purpose of the LOTS is mainly for obtaining an understanding of the RSW process, its use for predicting schedules for actual welding practice is limited. The law does not hold well in welding sheets of dissimilar thicknesses as it only considers the total thickness of the stack up and does not account for the individual thicknesses of the sheets. The LOTS does not consider the effect of the actual heat input to make a weld. A welding experiment carried out by the authors on uncoated mild carbon steel highlights the differences between handbook-suggested schedules and those predicted by the LOTS, as seen in Table 1.

In Table 1, three materials of different thickness were welded using schedules obtained from the *Welding Handbook* (Ref. 6) and from the LOTS. The schedules based on LOTS for welding a particular thickness are derived from the schedules for welding the other two materials (selected using the schedules from the *Welding Handbook* (Ref. 6)). For instance, a schedule for welding 0.75-mm steel can be obtained directly from the *Welding Handbook* (Ref. 6) (first row of Table 1), or it can be derived using LOTS based on proven schedules (provided by the *Welding Handbook*) (Ref. 6) on 1.21-mm steel and 1.89-mm steel (second and third rows of Table 1). A good welding schedule is defined as the one that yields a large weld without expulsion. It can be clearly seen that there is a large difference between the weld schedules suggested by the *Welding Handbook* (Ref. 6) and those predicted by the LOTS; and the former are usually more realistic and yield significantly better

welds than the latter. Due to the limitations mentioned above, the LOTS cannot be directly used for practical welding as it was not intended for such a purpose in the first place.

A new theory is proposed in this work to overcome some of these limitations. The weld schedules predicted as per the new theory are based on heat balance equations and are, therefore, closer than the LOTS to the actual physical welding conditions. Besides providing more accurate welding schedules, the theory can accommodate different sheet thicknesses in a single stack up, and is thus closer to the practical welding scenario.

### Heat Balance

In RSW, heat balance can be defined as a condition in which the fusion zones on both pieces being joined undergo approximately the same degree of heating and pressure application (Ref. 7). It describes the ideal situation when a symmetric weld (with equal depth of nugget penetration) is made. Heat balance is influenced by the relative thermal and electrical conductivities of the materials to be joined, the geometry of the weldment, the thermal and electrical conductivities, and the geometry of the electrodes.

A heat balance can be achieved if two identical sheets are welded together with electrodes of equal mass and contour and heat is generated in both the pieces uniformly, with an oval-shaped weld cross section. However, if one of the pieces has higher electric resistivity than the other, heat will be generated more rapidly in this piece, resulting in a less-than-perfect weld depending upon the amount of heat imbalance. In the case of dissimilar metals,

such as when welding plain carbon steel to stainless steel, this dissimilarity can be compensated for by increasing the electrode contact area on the high-resistivity stainless steel side, or by using an electrode material of higher resistance on the low-resistivity carbon steel side. In the case of similar metals of unequal thickness, proper heat balance can be achieved by using a smaller contacting electrode area on the thinner sheet, with short times and high current densities (Refs. 7, 8).

## Proposed Theory

The basic idea of the theory proposed in this work is that the total heat needed to create a weldment can be partitioned into those needed for the fusion zone, the heat-affected zone (HAZ), and the indented area, where significant amount of heat is required. Instead of considering the thickness of the entire stack up (as by the LOTS), the heat input into each of the zones of the stack up is accounted for. Therefore, rather than treating it as an entity, the weldment is split into different zones for heat calculation. Such a division is necessary when the sheets have different thicknesses, material properties, etc. So, for a two-sheet stack up, there are two nugget zones at the center, surrounded on either side by a heat-affected zone and an outer indentation zone, as shown in Fig. 1.

The basic equation for heat calculation during heating a solid or a liquid is

$$Q = m \times C_p \times \Delta T \quad (6)$$

where  $m$  is the mass,  $C_p$  is the specific heat of the material, and  $\Delta T$  is the change in temperature due to heating. Each zone is idealized as a short cylinder for simplicity. For instance, assuming the HAZ has the same diameter as the electrode face, the mass of the HAZ can be expressed as

$$m = \frac{\pi}{4} \times d_e^2 \times h \times \rho \quad (7)$$

where  $d_e$  is the electrode diameter,  $h$  is the height of the HAZ, and  $\rho$  is the density of the sheet. Then the heat in the HAZ can be calculated using Equation 6.

The heat components can be calculated once the mass, thermal properties, and the possible maximum temperature increases are known. The volumes of various zones in a weldment are generally different. However, an assumption that the zones are (short) cylinders of the same diameter but different heights is made in this study for simplicity. Actually, their diameters are not much different for a well-controlled grown weld. The electrode diameter  $d_e$  can be used as the diameter of

all the zones (cylinders). A nominal value was used for  $d_e$  as their sizes usually vary during welding, and the size of a weld is desired to be close to that of the electrodes. For the indentation, heat is accounted for by assuming two (empty) cylinders of indentation experience a heating from room temperature up to (but below) melting temperature. It comprises the contribution from both sides of the weldment

$$q1 = \frac{\pi}{4} d_e^2 \rho_1 C_{p1} h_1 \Delta T_1 \quad (8)$$

$$q6 = \frac{\pi}{4} d_e^2 \rho_2 C_{p2} h_6 \Delta T_6 \quad (9)$$

where  $\Delta T_1 = \Delta T_6 = T_{melt} - T_{amb}$ , the difference between the melting temperature and room temperature,  $d_{e1}$  and  $d_{e2}$  are the face diameters of the electrodes on both sides,  $C_{p1}$  and  $C_{p6}$  are the specific heats of the respective materials, and  $h_1$  and  $h_6$  are the depths of indentations, respectively, for the upper and lower sheets.

Similarly for the heat-affected zone, the heat inputs on both sides are

$$q2 = \frac{\pi}{4} d_e^2 \rho_1 C_{p1} h_2 \Delta T_2 \quad (10)$$

$$q5 = \frac{\pi}{4} d_e^2 \rho_2 C_{p2} h_5 \Delta T_5 \quad (11)$$

where  $\Delta T_2 = \Delta T_5 = T_{melt} - T_{amb}$  and  $d_e$  is the electrode diameter, which is used as an approximation for the diameter of the HAZ.

The solid-liquid phase transformation takes place in the nugget zone, and the heat input during melting needs to be calculated separately. The heat of the nugget includes that required for heating the metal from room temperature to the melting point, the latent heat required for melting, and the heat needed to raise the temperature beyond the melting point of the metal. The density and specific heat are different for each stage. However, the specific heat was found to be almost identical for all three stages, and hence can be assumed constant.

Let

$$q3 = \frac{\pi}{4} d_e^2 h_3 \left[ \rho_1 C_{p1} (T_{melt} - T_{amb}) + \rho_1' L_{f1} + \rho_1'' C_{p1} (T_{max} - T_{melt}) \right] \quad (12)$$

$$q4 = \frac{\pi}{4} d_e^2 h_4 \left[ \rho_2 C_{p2} (T_{melt} - T_{amb}) + \rho_2' L_{f2} + \rho_2'' C_{p2} (T_{max} - T_{melt}) \right] \quad (13)$$

be the heat input to the two halves of the nugget, where  $h_3$  and  $h_4$  are the heights of

the fusion zone in each sheet,  $\rho_1'$  and  $\rho_2'$  are the liquid densities at melting temperature,  $\rho_1''$  and  $\rho_2''$  are the average densities,  $C_{p1}'$  and  $C_{p2}'$  are the average specific heats of the liquid between  $T_{max}$  and  $T_{melt}$ , and  $L_{f1}$  and  $L_{f2}$  are the latent heats of fusion.

The total heat used to make the weldment =  $q = q1 + q2 + q3 + q4 + q5 + q6$ , or

$$\begin{aligned} q = & \frac{\pi}{4} d_e^2 \rho_1 C_{p1} h_1 \Delta T_1 \\ & + \frac{\pi}{4} d_e^2 \rho_1 C_{p1} h_2 \Delta T_2 + \frac{\pi}{4} d_e^2 h_3 \\ & \left[ \rho_1 C_{p1} (T_{melt} - T_{amb}) \right. \\ & \left. + \rho_1' L_{f1} + \rho_1'' C_{p1} (T_{max} - T_{melt}) \right] \\ & + \frac{\pi}{4} d_e^2 h_4 \left[ \rho_2 C_{p2} (T_{melt} - T_{amb}) + \right. \\ & \left. \rho_2' L_{f2} + \rho_2'' C_{p2} (T_{max} - T_{melt}) \right] \\ & + \frac{\pi}{4} d_e^2 \rho_2 C_{p2} h_5 \Delta T_5 \\ & + \frac{\pi}{4} d_e^2 \rho_2 C_{p2} h_6 \Delta T_6 \end{aligned} \quad (14)$$

Based on the heat components calculated, a characteristic dimension  $H$  is defined as

$$\begin{aligned} H = & h_1 \frac{q1}{q} + h_2 \frac{q2}{q} + h_3 \frac{q3}{q} \\ & + h_4 \frac{q4}{q} + h_5 \frac{q5}{q} + h_6 \frac{q6}{q} \end{aligned} \quad (15)$$

This characteristic dimension is used instead of the actual thickness of the entire stack up (as used in the LOTS) as it differentiates the contributions of various regions in an actual heating process. Although they are closely related in the physical process,  $h_i$  ( $i = 1...6$ ) are independently defined, and they can be altered independently to obtain the desired features of a weldment.

This theory was verified in the case of developing welding schedules for uneven-thickness sheet stack ups. The first step is to develop good schedules for welding even-thickness sheet stack ups. One can use proven, good welding schedules for equal thickness sheets, such as those listed in the *Welding Handbook* (Ref. 6). The schedules for welding uneven-thicknesses can then be developed using those for welding even-thickness sheets and this theory.

For even thickness stack up, the weld time, welding current, electrode force, and electrode diameters were chosen from the *Welding Handbooks* (Refs. 6, 7), as shown in Table 2.

For a sheet stack up, the heat input needed for making a weldment is propor-

**Table 2 — Welding Handbook Schedules for Uncoated Low-Carbon Steel Sheets (Refs. 6, 7)**

Sheet Thickness (mm)	Welding Current (A)	Weld Time (ms/cyc)	Electrode Force (kg/lb)	Electrode Diameter (mm)
0.508	8500	117/7	181/400	4.78
0.635	9500	133/8	204/450	4.78
0.762	10500	150/9	227/500	6.35
0.889	11500	150/9	272/600	6.35
1.016	12500	167/10	317/700	6.35
1.143	13000	183/11	340/750	6.35
1.270	13500	200/12	363/800	7.92
1.397	14000	217/13	408/900	7.92
1.524	15000	233/14	454/1000	7.92
1.778	16000	267/16	544/1200	7.92
2.032	17000	300/18	635/1400	7.92
2.286	18000	333/20	726/1600	9.53
2.667	19500	383/23	816/1800	9.53
3.048	21000	467/28	952/2100	9.53

tional to the square of welding current, weld time, and the resistance offered by the sheet material (Ref. 8)

$$q \propto I^2 \times R \times \tau \quad (16)$$

The resistance in turn can be assumed proportional to the characteristic dimension of the stack up and inversely proportional to the square of the nugget diameter, as assumed by other researchers (Ref. 9)

$$R \propto \frac{H}{d_e^2} \quad (17)$$

Therefore,

$$q \propto I^2 \times \frac{H}{d_e^2} \times \tau \quad (18)$$

The derivation of these equations does not consider the heat loss through the electrodes and sheets (a variable during welding), which is obviously an approximation, as this heat takes a large portion of the total heat generated during welding. Only the total heat needed to create various dimensions of a weldment is taken into consideration in this study.

Consider a case of two-sheet welding. Let  $I_1, H_1, \tau_1, de_1,$  and  $F_1$  be the current, characteristic dimension, time, nugget diameter, and electrode force, respectively, for one stack up, and  $I_2, H_2, \tau_2, de_2,$  and  $F_2$  be the current, characteristic dimension, time, nugget diameter, and electrode force, respectively, for another stack up. Based on the assumption the amount of heat needed to make the uneven-thickness welding is the sum of one-half of that for thin even-thickness welding and one-half of that for thick even-thickness weld-

ing, the parameters for uneven-thickness welding can be approximated as

$$H_3 = \frac{\frac{I_1^2 \times H_1 \times \tau_1}{d_{e1}^2} + \frac{I_2^2 \times H_2 \times \tau_2}{d_{e2}^2}}{\frac{I_1^2 \times \tau_1}{d_{e1}^2} + \frac{I_2^2 \times \tau_2}{d_{e2}^2}} \quad (19)$$

$$\tau_3 = \frac{\frac{I_1^2 \times H_1 \times \tau_1}{d_{e1}^2} + \frac{I_2^2 \times H_2 \times \tau_2}{d_{e2}^2}}{H_3 \times \left( \frac{I_1^2}{d_{e1}^2} + \frac{I_2^2}{d_{e2}^2} \right)} \quad (20)$$

$$I_3^2 = \frac{\frac{I_1^2 \times H_1 \times \tau_1}{d_{e1}^2} + \frac{I_2^2 \times H_2 \times \tau_2}{d_{e2}^2}}{H_3 \times \tau_3 \times \left( \frac{1}{d_{e1}^2} + \frac{1}{d_{e2}^2} \right)} \quad (21)$$

As the electrode force is proportional to the square of the electrode diameter to keep a constant pressure (Ref. 8),

$$F \propto d_e^2 \quad (22)$$

Therefore,

$$F_3 = \frac{\frac{F_1}{d_{e1}^2} + \frac{F_2}{d_{e2}^2}}{\frac{1}{d_{e1}^2} + \frac{1}{d_{e2}^2}} \quad (23)$$

The temperature in the weldment is assumed proportional to the heat generated, and inversely proportional to the characteristic thickness and the square of the electrode diameter (Ref. 9) when the welds formed are similar

$$T \propto \frac{q}{H \times d_e^2} \quad (24)$$

As the zones in a weldment are assumed similar to their counterparts in the individual welds, Equation 24 can be used to approximate the temperature of a weldment. Let  $q_1$  and  $q_2$  be the total heat content of the two stacks, then, for the combination stack up, the heat content  $q_3$  is given by

$$q_3 = \frac{\frac{q_1}{H_1 \times d_{e1}^2} + \frac{q_2}{H_2 \times d_{e2}^2}}{\frac{1}{H_3} \times \left( \frac{1}{d_{e1}^2} + \frac{1}{d_{e2}^2} \right)} \quad (25)$$

## Experiment

Experiments were carried out to verify the theory and prove it suitable for use as a guideline for selecting welding schedules not listed in the *Welding Handbook*. The experiments were conducted on a resistance spot welding machine equipped with a programmable weld control unit. A 35-KVA transformer was used along with a "C" type gun. The raw material used was bare mild carbon steel sheets of 14- (0.75-mm), 18- (1.21-mm), and 22- (1.89-mm) gauge of ASTM A569 and ASTM A366 grade.

Ambient temperature = 27°C, melting point for mild steel = 1535°C, maximum temperature reached was assumed to be 1735°C (with 200°C overheating), specific heat of mild steel = 252914.79 J/kg°C, latent heat of fusion = 241585.5 J/kg, the average density of mild steel between room temperature (27°C) and melting temperature (1535°C) is 7470 kg/m<sup>3</sup>, (liquid) density at 1535°C = 7190 kg/m<sup>3</sup>, density at 1735°C = 6991 kg/m<sup>3</sup> (Refs. 10–12). Several sets of welds were made with the calculated schedules based on the schedules for even-thickness sheet welding listed in the *Welding Handbook* (Ref. 6). The welds were peel tested and the weld diameter was measured. Samples were prepared for metallographic examination and measuring various dimensions. With the help of these measured dimensions, the welding parameters for other sheets were predicted using the equations of the proposed theory. Then using these predicted weld parameters, new sets of welds were made,

**Table 3 — Experiment Results**

Expt No.	Thickness (mm)	Electrode Diameter (mm)	Welding Current (A)	Weld Time (ms/cyc)	Electrode Force (kg/lb)	Heat (Joules)	Charac. Thickness (mm)	Minimum Weld Diameter (mm) <sup>(a)</sup>	Average Weld Diameter (mm)
1	0.75 + 0.75	6.35	9750	150/9	227/500	840095	0.468	3.43	5.302
2	1.21 + 1.21	7.14	13500	200/12	354/780	1416971	0.749	4.58	7
Prediction	0.75 + 1.21	6.35/7.14	11557	180/10.81	283/624	1205616	0.656	3.43	—
3	0.75 + 1.21	6.35/7.14	10500	183/11	286/630	1135177	0.665	3.43	5.9

(a) The minimum weld size required as listed in the Welding Handbook (Ref. 6)

and the procedure was repeated. Finally, the weld parameters obtained from welding schedules predicted by the proposed theory were compared with those obtained in actual welding.

### Results and Discussion

First, even-thickness sheets of 0.75 and 1.21 mm thicknesses were welded, with schedules very close to the ones given in the *Welding Handbook* (Ref. 6). The weld diameter was measured, and microscopic observations revealed the thicknesses of various zones for calculating the characteristic dimensions. From this data, weld schedules for a stack of 0.75- +1.21- mm sheets were predicted using the equations of the proposed theory. Welding using these schedules yielded the expected weld sizes without expulsion. The results are tabulated in Table 3.

In Table 3, the current in the experiment (No. 3) was searched, based on the predicted value, to obtain a similar characteristic height as the predicted. This practice was to show that a characteristic height (and, therefore, a weldment) can be created in welding using schedules derived by the theory. The table reveals the experimental results obtained for the uneven-thickness combination are in good agreement with those predicted by the theory. The welding schedules predicted by the proposed theory yielded a good weld in terms of size and surface quality. Several additional tests were carried out to further verify the results of the proposed theory and build a confidence interval on its ability to predict correct weld schedules.

Using the same welding schedule, several welds were made and the weld size was measured to establish a variance on the weld diameter. The variance on the mean diameter of the welds was found to be very small ( $\mu_d = 4.93$ ,  $\sigma^2 = 0.0514$ ).

With all other weld parameters kept constant, the weld time was varied over a range. It was confirmed the weld by the selected schedule had the largest size without expulsion. Weld times below the selected one resulted in undersize welds, while weld times above the chosen one led to expulsion.

With all other weld parameters kept constant, the weld current was varied over a range. It also proved that the weld current at the schedule selected gave the largest nugget size without expulsion. Again, lower than selected currents gave a smaller weld button while expulsion occurred for higher currents.

Experiments have shown the predicted welding parameters used are optimized to have the largest weld diameter without expulsion. The parameters can be predicted with 98% confidence. Thus the theory helps to predict welding schedules for uneven-thickness sheets with good accuracy and ease for practical use.

### Summary

A new theory based on heat balance was proposed for developing schedules in welding uneven-thickness sheet combinations. It takes into account the heat input into the fusion zone, the HAZ, and the electrode indentation and uses basic proportionality equations to reflect their contributions in welding to predict the welding parameters. The proposed theory was verified experimentally, and it provides a simple guideline for selecting weld schedules for uneven-thickness, two-sheet metal welding, based on those of even-thickness schedules. The theory and the procedure can be implemented in a production environment and can serve as a ready reference for choosing welding parameters on the shop floor.

#### Acknowledgment

This work was partially supported by the University Research Awards and Fellowships grant (URAF 480308) of The University of Toledo.

#### References

1. Li, W. 1999. Monitoring and diagnosis of resistance spot welding process. Ph.D. diss., University of Michigan.
2. *Resistance Welding Manual*. 1989. Resistance Welder Manufacturers' Association (RWMA), 4th ed.
3. Okuda, T. 1973. Spot welding of thick plates, part 1: The law of thermal similarity,

Yosetsu Gujutsu, *Japanese Welding Society*, 21 (9).

4. Fong, M., Tsang, A., and Ananthanarayanan, A. 2000. Development of the law of thermal similarity (LOTS) for low indentation cosmetic resistance welds. *Sheet Metal Welding Conference IX*, Paper 5-6, Detroit, Mich.

5. Ando, K., and Nakamura, T. 1957. On the thermal time constant in resistance spot welding: report 1. *Japanese Welding Society*, 26 (9).

6. Welding Processes. *Welding Handbook*, 8th ed., Vol. 2, 1991. Miami, Fla.: American Welding Society.

7. *Welding Handbook*, 2nd ed., 1942. New York, N.Y.: American Welding Society.

8. Welding Technology. *Welding Handbook*, 8th ed., Vol. 1, 1987. Miami, Fla.: American Welding Society.

9. Matsuyama, K., and Chun, J. 2000. A study of splashing mechanism in resistance spot welding. *Sheet Metal Welding Conference IX*, Paper 5-4, Detroit, Mich.

10. Alloys. *Handbook of Thermophysical Properties of Solid Materials*, Vol. 2, 1961. Edited by A. Goldsmith., T. Waterman, and H. Hirschhorn.

11. *Metals Handbook*, 1984. Edited by H. Boyer and T. Gall. Materials Park, Ohio: American Society for Metals International.

12. Cezairliyan, A., and Anderson, A. *Specific Heat of Solids*, 1988. Edited by C. Ho. New York, N.Y.: Hemisphere Pub. Corp.

## REPRINTS REPRINTS

To order custom reprints of  
articles in

*Welding Journal*

Contact Denis Mulligan at

(800) 259-0470

FAX: (717) 481-7677

or via e-mail at

info@reprintdept.com

## REPRINTS REPRINTS