

ITEM	DESCRIPTION	QTY.	REMARKS
A	11mm [3/8"] x 75mm [3"] x 181mm [7"]	Z	31° Bevel one edge
B	16mm [5/8"] x 75mm [3"] x 181mm [7"]	Z	31° Bevel one edge
C	4 hch Sch 61 Pipe X 4" 31° bevel one end	Z	31° Bevel one end

2009 AWS SkillsUSA
Weld Trials
Kansas City, MO

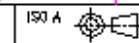

Scale NONE

Name	PROJECT TASK FILLET WELD A & B		
Trade	10	WELDING	
Revision	0		
Sheet	1 of 1		

TACK WELDS NOT GREATER THAN 25mm LONG.
1 ON EACH END

Test Pieces 10mm X 100mm X 225mm

Fillet Weld A _____ Fillet Weld B _____

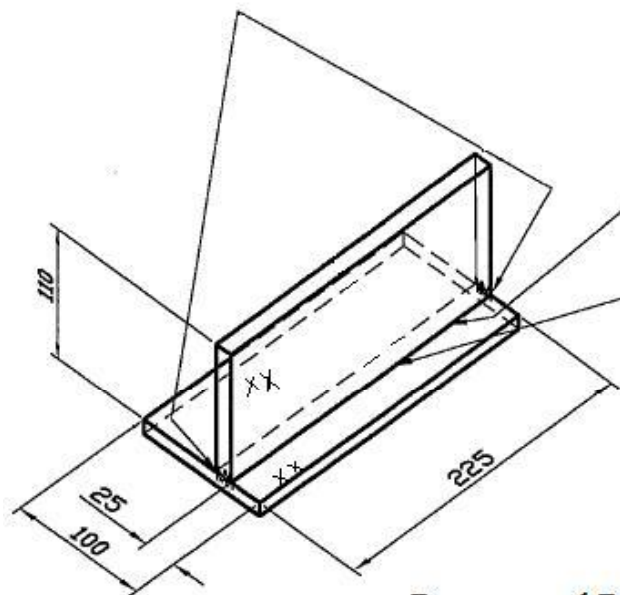

2F and 4F FILLET WELD
SHALL BE MADE IN
3 RUNS

EACH RUN OF WELD TO BE
STOPPED & RESTARTED
WITHIN THE CENTRAL 50mm

1F and 3F FILLET WELD SHALL
BE MADE WITH A MIN
OF 2 RUNS

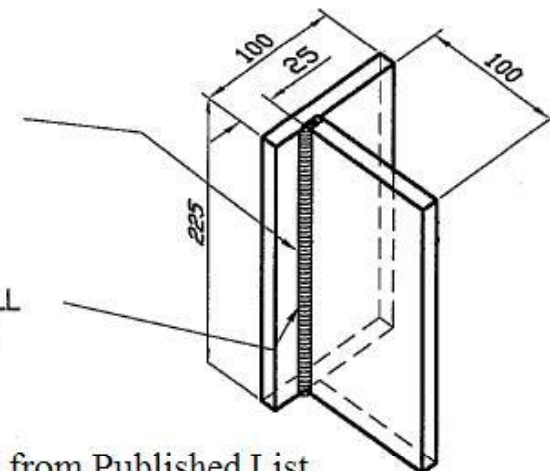

Stamp ID # and
Date Each Test
Piece at XX's

Process and Position will be Randomly Selected from Published List

All Fillet Welds will be 10mm in size +1mm or -1mm