



AMERICAN WELDING SOCIETY
WELDING INSPECTOR EXAMINATION

Part B

EXAMINATION BOOK OF SPECIFICATIONS

TABLE OF CONTENTS

Appendices

	<u>Page No.</u>
I. Welding Procedure Qualification Record (PQR)	4
II-A. Performance Qualification Test Record	6
II-B. Welder Performance Qualification Record (Example)	8
III. Prequalified Complete Joint Penetration Groove Welded Joints	10
IV. Pipe Schedules	12
V. Acceptable and Unacceptable Weld Profiles	14
VI. Weld Profile Acceptance Description	16
VII. Visual Weld Inspection Acceptance Criteria	17
VIII. Test Results Required, Guided Bends	19
IX. Weld Metal Analysis	20
X. Electrode Groups	21
XI. Welder Qualification Test Requirements	25
XII. Fillet Procedure Qualification Requirements	29
XIII. Groove Procedure Qualification Requirements	30
XIV. Prequalified Base Metal—Filler Metal Combinations for Matching Strength	32
XV. Minimum Preheat and Interpass Temperature	38
XVI. Radiographic Testing	42
XVII. Face and Root Bend Specimens	50

Revision D: January 2006 with editorial corrections of December 2008



AMERICAN WELDING SOCIETY
WELDING INSPECTOR EXAMINATION

Part B

EXAMINATION BOOK OF SPECIFICATIONS

目录

附录

页码

I.	焊接工艺评定试验记录	5
II-A.	焊工资格考试试验记录	7
II-B.	焊工技能评定记录(范例)	9
III.	免除评定的全焊透坡口焊接接头	11
IV.	管子公称等级	13
V.	可接收的和不可接收的焊缝外形	15
VI.	焊缝外形验收准则	16
VII.	焊缝目视检查验收准则	18
VIII.	导向弯曲试验要求	19
IX.	焊缝金属分析	20
X.	焊条分组	22
XI.	焊工评定试验要求	26
XII.	角焊缝工艺评定要求	29
XIII.	坡口焊缝工艺评定要求	31
XIV.	免除评定的母材 - 填充金属匹配要求	33
XV.	最低预热和层间温度	39
XVI.	射线探伤	43
XVII.	面弯和背弯试样	51

版本D: 2008年12月对2006年1月版本修订

Conversions and Calculations

The International System of Units (SI) makes use of conversion factors and metric prefixes. Use the following tables:

Table of SI Conversions

PROPERTY	U.S. CUSTOMARY UNITS	SI UNITS	
	<i>To convert from</i>	<i>To</i>	<i>Multiply by</i>
force	pound-force (lbf)	newton (N)	4.5
	kip (1000 lbf)	newton	4450
linear dimension	inch (in)	millimeter (mm)	25.4
tensile strength	pounds per square inch (psi)	pascal (Pa)	6895
	(psi)	kilopascal (kPa)	6.89
	(psi)	megapascal (MPa)	0.00689
mass	pound mass (avdp)	kilogram	0.454
angle, plane	degree (angular) (°)	radian (rad)	0.0175
flow rate	cubic feet per hour (ft ³ /hr)	liters per minute (L/min)	0.472
heat input	joules per inch (J/in)	joules per meter (J/m)	39.4
travel speed, wire	inches per minute (in/min)	millimeter per second (mm/s)	0.423
temperature	degree Fahrenheit (°F)	degree Celsius (°C)	°C = (°F - 32)/1.8

Table of SI Prefixes

EXPONENTIAL EXPRESSION	MULTIPLICATION FACTOR	PREFIX	SYMBOL
10 ⁹	1 000 000 000	giga	G
10 ⁶	1 000 000	mega	M
10 ³	1 000	kilo	k
10 ⁻³	0.001	milli	m
10 ⁻⁶	0.000 001	micro	μ
10 ⁻⁹	0.000 000 001	nano	n

Formulas

PROPERTY	FORMULA		
ultimate tensile strength (uts)	uts = maximum load/original cross-sectional area		
cross-sectional area (csa)	csa = $\pi D^2/4$ (for circle) csa = width × thickness (for square or rectangle)		
temperature	degree Fahrenheit (°F)	degree Celsius (°C)	°C = (°F - 32)/1.8
	degree Celsius (°C)	degree Fahrenheit (°F)	°F = 1.8 × °C + 32

换算和计算

公制单位(SI)使用转换系数和公制前缀。使用下列表格:

公制单位换算表

名称	美国惯用单位	公制单位	
	从...转化	转化为	乘以
力	磅	牛顿	4.5
	千磅	牛顿	4450
线性尺寸	英寸	毫米	25.4
拉伸强度	英磅每平方英寸	帕	6895
	英磅每平方英寸	千帕	6.89
	英磅每平方英寸	兆帕	0.00689
质量	质量磅	千克	0.454
角, 平面	度	弧度	0.0175
流量	立方尺每小时	升每分钟	0.472
热输入	焦耳每英寸	焦耳每米	39.4
焊接速度, 焊丝	英寸每分钟	毫米每分钟	0.423
温度	华氏度	摄氏度	$^{\circ}\text{C} = (^{\circ}\text{F} - 32)/1.8$

公制单位前缀表

指数	乘数	前缀	符号
10^9	1 000 000 000	吉	G
10^6	1 000 000	兆	M
10^3	1 000	千	k
10^{-3}	0.001	毫	m
10^{-6}	0.000 001	微	μ
10^{-9}	0.000 000 001	纳	n

公式

名称	公式	
抗拉强度 (uts)	$\text{uts} = \text{最大载荷}/\text{原始截面积}$	
截面积 (csa)	$\text{csa} = \pi D^2/4$ (对圆形) $\text{csa} = \text{宽度} \times \text{厚度}$ (对正方形或矩形)	
温度	华氏度	
	摄氏度	
	摄氏度	$^{\circ}\text{C} = (^{\circ}\text{F} - 32)/1.8$
	华氏度	$^{\circ}\text{F} = 1.8^{\circ}\text{C} + 32$

**This book is for examination purposes only.
It is not a working set of specifications nor a code.**

此书仅用于考试的目的。

这不是一套工作用的技术要求也不是一个技术规范。

**The information contained herein may not match
the current editions of the referenced documents.**

本书包含的资料内容

可能和现行的参考文件并不相符。

Do not write in this book.

请不要在此书上书写。

APPENDIX I

WELDING PROCEDURE QUALIFICATION RECORD (PQR)

PROCEDURE SPECIFICATION

Material specification _____ [1]
 Welding process _____ [2]
 Manual, semiautomatic, automatic: _____ [3]
 Position of welding _____ [4]

Filler metal specification _____ [5]
 Filler metal classification _____ [6]
 Weld metal analysis _____ [7]
 Shielding gas _____ [8]
 Flow rate _____ [9]
 Single or multiple pass _____ [10]
 Single or multiple arc _____ [11]
 Welding current _____ [12]
 Welding progression _____ [13]
 Preheat temperature _____ [14]
 Welder's ID _____ [15]
 Welder's name _____ [16]

GROOVE WELD TEST RESULTS

Tensile Strength, psi

1. _____ [24]
 2. _____ [25]

Guided-Bend Tests (2 root-, 2 face-, or 4 side-bends)

Root	Face	Side
1. _____ [26]	1. _____ [28]	1. _____ [30]
2. _____ [27]	2. _____ [29]	2. _____ [31]
		3. _____ [32]
		4. _____ [33]

Radiographic-Ultrasonic Examination

RT Report No: _____ [34]
 UT Report No: _____ [35]

VISUAL INSPECTION RESULTS

Appearance _____ [17]
 Undercut _____ [18]
 Piping porosity _____ [19]

FILLET WELD TEST RESULTS

Minimum size multiple pass	Maximum size single pass
Macroetch	Macroetch
1. _____ [36]	1. _____ [39]
2. _____ [37]	2. _____ [40]
3. _____ [38]	3. _____ [41]

ALL-WELD-METAL TENSION TEST RESULTS

Tensile strength, psi _____ [20]
 Yield point/strength, psi _____ [21]
 Elongation in 2 in, % _____ [22]
 Laboratory Test No: _____ [23]

Test Date _____ [42]
 Witnessed by _____ [43]

WELDING PROCEDURE

Pass No.	Electrode Size	Welding Current		Speed of Travel	Joint Detail
		Amperes	Volts		
[44]	[45]	[46]	[47]	[48]	[49]

We, the undersigned, certify that the statements in this record are correct.

Procedure No. _____ [50]
 Revision No. _____ [52]

Manufacturer or Contractor _____ [51]
 Authorized by _____ [53]
 Date _____ [54]

附录 I

焊接工艺评定试验记录 (PQR)

<p style="text-align: center;">工艺规范</p> <p>材料规范 _____ [1]</p> <p>焊接方法 _____ [2]</p> <p>手工, 半自动, 自动 _____ [3]</p> <p>焊接位置 _____ [4]</p> <p>填充金属规范 _____ [5]</p> <p>填充金属分类 _____ [6]</p> <p>焊缝金属分析 _____ [7]</p> <p>保护气体 _____ [8]</p> <p>流量 _____ [9]</p> <p>单道或多道 _____ [10]</p> <p>单弧或多弧 _____ [11]</p> <p>焊接电流 _____ [12]</p> <p>焊接方向 _____ [13]</p> <p>预热温度 _____ [14]</p> <p>焊工识别号 _____ [15]</p> <p>焊工姓名 _____ [16]</p> <p style="text-align: center;">目视检验结果</p> <p>外观 _____ [17]</p> <p>咬边 _____ [18]</p> <p>管状气孔 _____ [19]</p> <p style="text-align: center;">全焊缝金属拉伸试验</p> <p>抗拉强度, psi _____ [20]</p> <p>屈服点/强度, psi _____ [21]</p> <p>2 英寸的延伸率, % _____ [22]</p> <p>试验室试验号 _____ [23]</p>	<p style="text-align: center;">坡口焊缝试验结果</p> <p>抗拉强度, psi</p> <p>1. _____ [24]</p> <p>2. _____ [25]</p> <p>导向弯曲试验 (2 个背弯, 2 个面弯, 或 4 个侧弯)</p> <table border="0" style="width: 100%;"> <tr> <td style="width: 33%;">背弯</td> <td style="width: 33%;">面弯</td> <td style="width: 33%;">侧弯</td> </tr> <tr> <td>1. _____ [26]</td> <td>1. _____ [28]</td> <td>1. _____ [30]</td> </tr> <tr> <td>2. _____ [27]</td> <td>2. _____ [29]</td> <td>2. _____ [31]</td> </tr> <tr> <td></td> <td></td> <td>3. _____ [32]</td> </tr> <tr> <td></td> <td></td> <td>4. _____ [33]</td> </tr> </table> <p>射线-超声波检测</p> <p>RT 报告号: _____ [34]</p> <p>UT 报告号: _____ [35]</p> <p style="text-align: center;">角焊缝试验结果</p> <table border="0" style="width: 100%;"> <tr> <td style="width: 50%;">多道焊最小尺寸</td> <td style="width: 50%;">单道焊最大尺寸</td> </tr> <tr> <td>宏观浸蚀</td> <td>宏观浸蚀</td> </tr> <tr> <td>1. _____ [36]</td> <td>1. _____ [39]</td> </tr> <tr> <td>2. _____ [37]</td> <td>2. _____ [40]</td> </tr> <tr> <td>3. _____ [38]</td> <td>3. _____ [41]</td> </tr> </table> <p>试验日期 _____ [42]</p> <p>见证人 _____ [43]</p>	背弯	面弯	侧弯	1. _____ [26]	1. _____ [28]	1. _____ [30]	2. _____ [27]	2. _____ [29]	2. _____ [31]			3. _____ [32]			4. _____ [33]	多道焊最小尺寸	单道焊最大尺寸	宏观浸蚀	宏观浸蚀	1. _____ [36]	1. _____ [39]	2. _____ [37]	2. _____ [40]	3. _____ [38]	3. _____ [41]
背弯	面弯	侧弯																								
1. _____ [26]	1. _____ [28]	1. _____ [30]																								
2. _____ [27]	2. _____ [29]	2. _____ [31]																								
		3. _____ [32]																								
		4. _____ [33]																								
多道焊最小尺寸	单道焊最大尺寸																									
宏观浸蚀	宏观浸蚀																									
1. _____ [36]	1. _____ [39]																									
2. _____ [37]	2. _____ [40]																									
3. _____ [38]	3. _____ [41]																									

焊接工艺

焊道号	焊条尺寸	焊接电流		焊接速度	接头详图
		安培	伏特		
[44]	[45]	[46]	[47]	[48]	[49]

我们(在下面签名的人)证实在此记录中的声明是正确的。

工艺号 _____ [50]	制造商或承包商 _____ [51]
版本号 _____ [52]	授权人 _____ [53]
	日期 _____ [54]

APPENDIX II-A

PERFORMANCE QUALIFICATION TEST RECORD (SMAW, GMAW, GTAW, FCAW, SAW, OFW, PAW)

Name _____ [1] Welder Welding Operator
 I.D. No. _____ [2] WPS Used _____ [3]
 Process(es) _____ [4] Transfer Mode (GMAW) _____ [5]
 Test Base Metal Specification _____ [6] to _____ [7]
 Material Number _____ [8] to _____ [9]
 Fuel Gas (OFW) _____ [10]
 AWS Filler Metal Classification(s) _____ [11] F No. _____ [12]
 Backing Yes No Double Side Single Side
 Current Polarity AC DCEP DCEN
 Consumable Insert Yes No Backing Gas Yes No

Test Joint Sketch

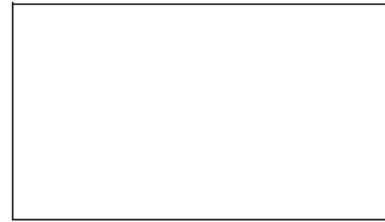

Test Weldment		Position Tested					Width (W)	Thickness (T)
Groove	Pipe	1G	2G	5G	6G		Thickness	Diameter
	Plate	1G	2G	3G	4G		Thickness	
Fillet	Pipe	1F	2F	2FR	4F	5F	Thickness	Diameter
	Plate	1F	2F	3F	4F		Thickness	
Cladding		1C	2C	3C	4C	5C	6C	Thickness
Hardfacing		1C	2C	3C	4C	5C	6C	Thickness

Progression Vertical Up Vertical Down

TEST RESULTS

REMARKS

Visual Test	Pass <input type="checkbox"/>	Fail <input type="checkbox"/>	N/A <input type="checkbox"/>		[13]
Macro Test	Pass <input type="checkbox"/>	Fail <input type="checkbox"/>	N/A <input type="checkbox"/>		[14]
Break Test	Pass <input type="checkbox"/>	Fail <input type="checkbox"/>	N/A <input type="checkbox"/>		[15]
Bend Test	Pass <input type="checkbox"/>	Fail <input type="checkbox"/>	N/A <input type="checkbox"/>		[16]
Radiographic Test	Pass <input type="checkbox"/>	Fail <input type="checkbox"/>	N/A <input type="checkbox"/>		[17]

QUALIFICATION LIMITS

Process(es) _____

Weldment		Position					Deposited Thickness		
Groove	Pipe	F	H	V	O	All	t min.	t max.	Dia. min.
	Plate		H	V	O	All	t min.	t max.	
Cladding		F	H	V	O	All	t min.	t max.	
Hardfacing		F	H		O	All	t min.	t max.	
Weldment		Position					Base Metal Thickness		
Fillet	Pipe	F	H	V	O	All	T min.	T max.	Dia. min.
	Plate	F		V	O	All	T min.	T max.	

Progression Vertical Up Vertical Down

Base Metal M No(s). _____ [18]	Fuel Gas (OFW) _____ [19]
Filler Metal F No(s). _____ [20]	Backing Yes <input type="checkbox"/> No <input type="checkbox"/>
Current Polarity AC <input type="checkbox"/> DCEP <input type="checkbox"/> DCEN <input type="checkbox"/>	Consumable Insert Yes <input type="checkbox"/> No <input type="checkbox"/>
Backing Gas _____ [21]	Transfer Mode (GMAW) _____ [22]

We, the undersigned, certify that the statements in this record are correct.

Date tested _____ [23] Qualifier signature _____ [24]

Permission to reproduce granted by the American Welding Society.

附录 II-A 技能评定试验记录

(SMAW, GMAW, GTAW, FCAW, SAW, OFW, PAW)

姓名 _____ [1] 焊工 焊接操作工
 识别号 _____ [2] 所用焊接工艺指导书 WPS _____ [3]
 焊接方法 _____ [4] 过渡方式(GMAW) _____ [5]
 试验母材的材料规范 _____ [6] 和 _____ [7]
 材料号 _____ [8] 和 _____ [9]
 气体燃料(OFW) _____ [10]
 AWS 填充金属分类 _____ [11] F 号 _____ [12]
 衬垫 有 没有 双面焊 单面焊
 电流极性 交流 直流反接 直流正接
 可溶性嵌条 有 没有 背面气体 有 没有

试验接头草图

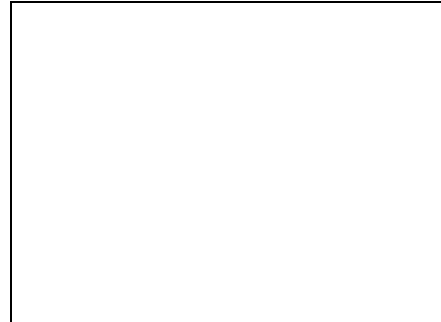

试验焊件	试验位置	宽度(W)	厚度(T)
坡口焊	管材	1G 2G 5G 6G	厚度 直径
	板材	1G 2G 3G 4G	厚度
角焊	管材	1F 2F 2FR 4F 5F	厚度 直径
	板材	1F 2F 3F 4F	厚度
复合层堆焊	1C 2C 3C 4C 5C 6C	厚度	
硬质合金堆焊	1C 2C 3C 4C 5C 6C	厚度	

焊接方向 立向上 立向下

试验结果

目视检查 合格 不合格 不适用
 宏观检验 合格 不合格 不适用
 折断试验 合格 不合格 不适用
 弯曲试验 合格 不合格 不适用
 射线探伤 合格 不合格 不适用

备注

 [13]

 [14]

 [15]

 [16]

 [17]

评定范围

焊接方法

焊件	位置	熔敷金属厚度
坡口焊	管材	平焊 横焊 立焊 仰焊 所有 tmin. tmax. Dia. min.
	板材	横焊 立焊 仰焊 所有 tmin. tmax.
复合层堆焊	平焊 横焊 立焊 仰焊 所有 tmin. tmax.	
硬质合金堆焊	平焊 横焊 仰焊 所有 tmin. tmax.	
焊件	位置	母材厚度
角焊	管材	平焊 横焊 立焊 仰焊 所有 Tmin. Tmax. Dia. min.
	板材	平焊 立焊 仰焊 所有 Tmin. Tmax.

焊接方向 立向上 立向下

母材 M 号 _____ [18] 气体燃料(OFW) _____ [19]
 填充金属 F 号 _____ [20] 衬垫 有 没有
 电流极性 交流 直流反接 直流正接 可溶性嵌条 有 没有
 背面气体 _____ [21] 过渡方式(GMAW) _____ [22]

我们(在下面签名的人)证实在此记录中的声明是正确的。

试验日期 _____ [23] 评定人签名 _____ [24]

APPENDIX II-B

SpecTec, Inc.

905 Ridge Way, Eastern, Somewhere 84328, xxx-yyy-zzzz, FAX xxx-yyy-zzzz

WELDER PERFORMANCE QUALIFICATION RECORD

Welder's Name C. W. Practical ID No. 222-33-4444 Date 11-08-00
 WPS No. D1.1-3G-U-CJP-B-307
 Welding Process FCAW Type Manual
 Specification or Code AWS D1.1:2000, Structural Welding Code-Steel

Base Metal

Material Spec/Type/Grade A 36 To: Material Spec/Type/Grade A 36
 Thickness 1 in Thickness Range Qualified 1/8 in-Unlimited
 Base Metal Preparation Base metal shall be clean and free of moisture, oil, dirt, paint, coatings, rust, scale. etc. Cleaning shall leave no residue.

Joint Welded Single V-Groove with steel backing
 Type of Weld Joint (See Figure 4.21, Test Plate for Unlimited Thickness)
 Bevel Angle 22.5° Root Face 0 Root Opening 1/4 in
 Backing Yes No Backing Type 1/4 x 1 in Steel Strap

Electrode
 F No. 4 Specification A 5.18 Classification E71T-1 Size Range 1/16th

Filler Metal
 F No. 4 Specification A 5.18 Classification E71T-1 Size Range 1/16th

Preheat
 Preheat 50°F min. Interpass Temperature Max. 400°F

Position
 Position 3G Progression Up

TEST RESULTS

Visual	Bends	Radiographic	Metallographic
Pass <input checked="" type="checkbox"/> Fail <input type="checkbox"/>	N/A <input type="checkbox"/> Pass <input checked="" type="checkbox"/> Fail <input type="checkbox"/>	N/A <input checked="" type="checkbox"/> Pass <input type="checkbox"/> Fail <input type="checkbox"/>	N/A <input checked="" type="checkbox"/> Pass <input type="checkbox"/> Fail <input type="checkbox"/>

Test conducted by _____ Laboratory test no. _____
 per _____ Test date _____

QUALIFIED FOR

Base Metal Group No.	Type Weld	Current	Backing	Penetration	Vertical
I(a) (Carbon and Low-Alloy Steel)	Single Side <input checked="" type="checkbox"/> Double Side <input type="checkbox"/>	AC <input type="checkbox"/> DCEN <input type="checkbox"/> DCEP <input checked="" type="checkbox"/>	With <input checked="" type="checkbox"/> Type <u>Steel</u> Open Root <input type="checkbox"/>	Complete <input checked="" type="checkbox"/> Partial <input type="checkbox"/>	Down <input type="checkbox"/> Up <input checked="" type="checkbox"/>

	Position				t, in		OD, in	
					Min.	Max.	Min.	Max.
Plate—Groove	1G <input checked="" type="checkbox"/>	2G <input checked="" type="checkbox"/>	3G <input checked="" type="checkbox"/>	4G <input type="checkbox"/>	1/8	Unlimited		
Pipe/Tube—Groove	1G <input checked="" type="checkbox"/>	2G <input checked="" type="checkbox"/>	5G <input type="checkbox"/>	6G <input type="checkbox"/>	1/8	Unlimited	Over 24	Unlimited
Plate—Fillet	1F <input checked="" type="checkbox"/>	2F <input checked="" type="checkbox"/>	3F <input checked="" type="checkbox"/>	4F <input type="checkbox"/>	1/8	Unlimited		
Pipe/Tube—Fillet	1F <input checked="" type="checkbox"/>	2F <input checked="" type="checkbox"/>	5F <input type="checkbox"/>	6F <input type="checkbox"/>	1/8	Unlimited		

The above individual is qualified to the above limits in accordance with AWS D1.1:2000, *Structural Welding Code—Steel*.

Qualified By John Smith Position Weld Supervisor Date 11-10-00
(signature)

附录 II-B

Spectec 公司

某地东部 84328, 山脊路 905 号, xxx-yyy-zzz, 传真 xxx-yyy-zzz

焊工技能评定试验记录

焊工姓名 C. W. Practical 识别号 222-33-4444 日期 11-08-00
 焊接工艺(WPS)编号 D1.1-3G-U-CJP-B-307
 焊接方法 药芯焊丝电弧焊(FCAW) 类型 手工
 技术要求或法规 AWS D1.1 2000 钢结构焊接规范

母材

材料规范/类型/级别 A36 和 材料规范/类型/级别 A36
 厚度 1 英寸 评定的厚度范围 1/8 英寸 - 无限制
 母材准备 母材必须要保持清洁并且没有潮湿, 油污, 灰尘, 油漆, 涂层, 铁锈, 氧化皮等. 清理后必须没有残留物存在.

焊接接头 带衬垫的单面 V 型坡口

接头类型 (见图 4.21, 厚度无限制的试板)
 单边坡口角度 22.5° 钝边 0 根部间隙 1/4 英寸
 衬垫 有 没有 衬垫类型 1/4 X 1 英寸 钢带

焊条

F 号 4 技术要求 A 5.18 类别 E71T-1 尺寸范围 1/16th

填充金属

F 号 4 技术要求 A 5.18 类别 E71T-1 尺寸范围 1/16th

预热

预热 最低 50°F 最高层间温度 400°F

焊接位置

焊接位置 3G 焊接方向 向上

试验结果

目视检查	弯曲	射线	金相
合格 <input checked="" type="checkbox"/> 不合格 <input type="checkbox"/>	不适用 <input type="checkbox"/> 合格 <input checked="" type="checkbox"/> 不合格 <input type="checkbox"/>	不适用 <input checked="" type="checkbox"/> 合格 <input type="checkbox"/> 不合格 <input type="checkbox"/>	不适用 <input checked="" type="checkbox"/> 合格 <input type="checkbox"/> 不合格 <input type="checkbox"/>

试验员 _____ 试验室试验编号 _____
 试验标准 _____ 试验日期 _____

评定范围

母材组号	焊缝类型	焊接电流	衬垫	焊透性	立焊方向
I(a) (碳钢和低合金钢)	单面 <input checked="" type="checkbox"/>	交流 <input type="checkbox"/>	有 <input checked="" type="checkbox"/>	完全焊透 <input checked="" type="checkbox"/>	向下 <input type="checkbox"/>
	双面 <input type="checkbox"/>	直流正接 <input type="checkbox"/>	类型 <u>钢</u>	部分焊透 <input type="checkbox"/>	向上 <input checked="" type="checkbox"/>
		直流反接 <input checked="" type="checkbox"/>	根部间隙 <input type="checkbox"/>		

	焊接位置				厚度, 英寸		外径, 英寸	
					最小	最大	最小	最大
	1G	2G	3G	4G				
坡口焊 - 板材	1G <input checked="" type="checkbox"/>	2G <input checked="" type="checkbox"/>	3G <input checked="" type="checkbox"/>	4G <input type="checkbox"/>	1/8	无限制		
坡口焊 - 管材	1G <input checked="" type="checkbox"/>	2G <input checked="" type="checkbox"/>	5G <input type="checkbox"/>	6G <input type="checkbox"/>	1/8	无限制	大于 24	无限制
角焊 - 板材	1F <input checked="" type="checkbox"/>	2F <input checked="" type="checkbox"/>	3F <input checked="" type="checkbox"/>	4F <input type="checkbox"/>	1/8	无限制		
角焊 - 管材	1F <input checked="" type="checkbox"/>	2F <input checked="" type="checkbox"/>	5F <input type="checkbox"/>	6F <input type="checkbox"/>	1/8	无限制		

上述焊工按 AWS D1.1 2000 钢结构焊接规范评定合格, 评定范围如上。

评定人 John Smith 职位 焊接监督 日期 11-10-00

APPENDIX III

PREQUALIFIED COMPLETE JOINT PENETRATION GROOVE WELDED JOINTS

Single-V-groove weld (2)
Butt joint (B)

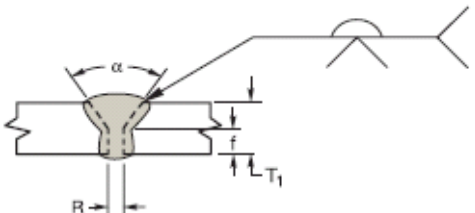

Welding Process	Joint Designation	Base Metal Thickness (U = unlimited)		Groove Preparation			Allowed Welding Positions	Gas Shielding for FCAW	Notes
		T ₁	T ₂	Root Opening Root Face Groove Angle	Tolerances				
					As Detailed	As Fitup			
SMAW	B-U2	U	—	R = 0 to 1/8 f = 0 to 1/8 $\alpha = 60^\circ$	+1/16, -0 +1/16, -0 +10°, -0°	+1/16, -1/8 Not limited +10°, -5°	All	—	b, c, d
GMAW FCAW	B-U2-GF	U	—	R = 0 to 1/8 f = 0 to 1/8 $\alpha = 60^\circ$	+1/16, -0 +1/16, -0 +10°, -0°	+1/16, -1/8 Not limited +10°, -5°	All	Not required	a, b, d
SAW	B-L2c-S	Over 1/2 to 1	—	R = 0 f = 1/4 max. $\alpha = 60^\circ$	R = ± 0 f = +0, -f $\alpha = +10^\circ, -0^\circ$	+1/16, -0 $\pm 1/16$ +10°, -5°	F	—	b, d
		Over 1 to 1-1/2	—	R = 0 f = 1/2 max. $\alpha = 60^\circ$					
		Over 1-1/2 to 2	—	R = 0 f = 5/8 max. $\alpha = 60^\circ$					

Single-V-groove weld (2)
Butt joint (B)

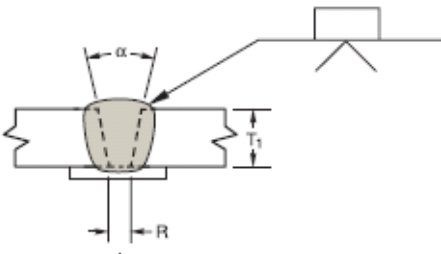

Tolerances	
As Detailed	As Fitup
R = +1/16, -0	+1/4, -1/16
$\alpha = +10^\circ, -0^\circ$	+10°, -5°

Welding Process	Joint Designation	Base Metal Thickness (U = unlimited)		Groove Preparation		Allowed Welding Positions	Gas Shielding for FCAW	Notes
		T ₁	T ₂	Root Opening	Groove Angle			
GMAW FCAW	B-U2a-GF	U	—	R = 3/16 R = 3/8 R = 1/4	$\alpha = 30^\circ$ $\alpha = 30^\circ$ $\alpha = 45^\circ$	F, V, OH F, V, OH F, V, OH	Required Not req. Not req.	a, d a, d a, d
SAW	B-L2a-S	2 max.	—	R = 1/4	$\alpha = 30^\circ$	F	—	d
SAW	B-U2-S	U	—	R = 5/8	$\alpha = 20^\circ$	F	—	d

^a Not prequalified for GMAW-S nor GTAW.

^b Backgouge root to sound metal before welding second side.

^c SMAW detailed joints may be used for prequalified GMAW (except GMAW-S) and FCAW.

^d The orientation of the two members in the joints may vary from 135° to 180° for butt joints, or 45° to 135° for corner joints, or 45° to 90° for T-joints.

附录 III

免除评定的全焊透坡口焊接接头

单面 - V 型坡口焊缝 (2) 对接接头 (B)									
焊接方法	接头名称	母材厚度 (U = 无限制)		坡口准备			允许的 焊接位置	FCAW 气体保护	注
		T ₁	T ₂	根部间隙 钝边 坡口角度	公差				
					零件用图	装配用图			
SMAW	B-U2	U	-	R=0 至 1/8 f=0 至 1/8 $\alpha=60^{\circ}$	+1/16, -0 +1/16, -0 +10 ⁰ , -0 ⁰	+1/16, -1/8 无限制 +10 ⁰ , -5 ⁰	全部	-	b, c, d
GMAW FCAW	B-U2-GF	U	-	R=0 至 1/8 f=0 至 1/8 $\alpha=60^{\circ}$	+1/16, -0 +1/16, -0 +10 ⁰ , -0 ⁰	+1/16, -1/8 无限制 +10 ⁰ , -5 ⁰	全部	不要求	a, b, d
SAW	B-L2c-S	大于 1/2 到 1	-	R=0 f=1/4 最大 $\alpha=60^{\circ}$	R=±0 f=+0, -f $\alpha=+10^{\circ}, -5^{\circ}$	+1/16, -0 ±1/16 +10 ⁰ , -5 ⁰	平焊	-	b, d
		大于 1 到 1-1/2	-	R=0 f=1/2 最大 $\alpha=60^{\circ}$					
		大于 1-1/2 到 2	-	R=0 f=5/8 最大 $\alpha=60^{\circ}$					

单面 - V 型坡口焊缝 (2) 对接接头 (B)									
焊接方法	接头名称	母材厚度 (U = 无限制)		坡口准备		公差			
		T ₁	T ₂	根部间隙	坡口角度	零件用图		装配用图	
						R=+1/16, -0	+1/4, -1/16	$\alpha=+10^{\circ}, -0^{\circ}$	+10 ⁰ , -5 ⁰
SMAW	B-U2a	U	-	R=1/4	$\alpha=45^{\circ}$	全部			
				R=3/8	$\alpha=30^{\circ}$	平焊, 立焊, 仰焊			
				R=1/2	$\alpha=20^{\circ}$	平焊, 立焊, 仰焊			
GMAW FCAW	B-U2a-GF	U	-	R=3/16	$\alpha=30^{\circ}$	平焊, 立焊, 仰焊			
				R=3/8	$\alpha=30^{\circ}$	平焊, 立焊, 仰焊			
				R=1/4	$\alpha=45^{\circ}$	平焊, 立焊, 仰焊			
SAW	B-L2a-S	最大 2	-	R=1/4	$\alpha=30^{\circ}$	平焊			
SAW	B-U2-S	U	-	R=5/8	$\alpha=20^{\circ}$	平焊			

^a GMAW-S 和 GTAW 不能免除评定。

^b 焊接背面焊缝前清根至完好金属。

^c SMAW 的接头细节可以用于免除评定的 GMAW(除 GMAW-S 以外)和 FCAW。

^d 接头中两部件的方位可在下述范围内变化, 对接接头: 135⁰ - 180⁰, 角接头: 45⁰ - 135⁰, T 型接头: 45⁰ - 90⁰。

APPENDIX IV

PIPE SCHEDULES

Pipe Size	O.D. (in)	5s	5	10s	10	20	30	40s Std.	40	60	80s & E.H.	80	100	120	140	160	Dble. E.H.
1/8	0.405		0.035 0.1383	0.049 0.1863	0.049 0.1863			0.068 0.2447	0.068 0.2447		0.095 0.3145	0.095 0.3145					
1/4	0.540		0.049 0.2570	0.065 0.3297	0.065 0.3297			0.088 0.4248	0.088 0.4248		0.119 0.5351	0.119 0.5351					
3/8	0.675		0.049 0.3278	0.065 0.4235	0.065 0.4235			0.091 0.5676	0.091 0.5676		0.126 0.7388	0.126 0.7388					
1/2	0.840	0.065 0.5383	0.065 0.5383	0.083 0.6710	0.083 0.6710			0.109 0.8510	0.109 0.8510		0.147 1.088	0.147 1.088				0.188 1.304	0.294 1.714
3/4	1.050	0.065 0.6838	0.065 0.6838	0.083 0.8572	0.083 0.8572			0.113 1.131	0.113 1.131		0.154 1.474	0.154 1.474				0.219 1.937	0.308 2.441
1	1.315	0.065 0.8678	0.065 0.8678	0.109 1.404	0.109 1.404			0.133 1.679	0.133 1.679		0.179 2.172	0.179 2.172				0.250 2.844	0.358 3.659
1-1/4	1.660	0.065 1.107	0.065 1.107	0.109 1.806	0.109 1.806			0.140 2.273	0.140 2.273		0.191 2.997	0.191 2.997				0.250 3.765	0.382 5.214
1-1/2	1.900	0.065 1.274	0.065 1.274	0.109 2.085	0.109 2.085			0.145 2.718	0.145 2.718		0.200 3.631	0.200 3.631				0.281 4.859	0.400 6.408
2	2.375	0.065 1.604	0.065 1.604	0.109 2.638	0.109 2.638			0.154 3.653	0.154 3.653		0.218 5.022	0.218 5.022				0.344 7.444	0.436 9.029
2-1/2	2.875	0.083 2.475	0.083 2.475	0.120 3.531	0.120 3.531			0.203 5.793	0.203 5.793		0.276 7.661	0.276 7.661				0.375 10.01	0.552 13.70
3	3.500	0.083 3.029	0.083 3.029	0.120 4.332	0.120 4.332			0.216 7.576	0.216 7.576		0.300 10.25	0.300 10.25				0.438 14.32	0.600 18.58
3-1/2	4.000	0.083 3.472	0.083 3.472	0.120 4.973	0.120 4.973			0.226 9.109	0.226 9.109		0.318 12.51	0.318 12.51				0.496 22.85	0.696 22.85
4	4.500	0.083 3.915	0.083 3.915	0.120 5.613	0.120 5.613			0.237 10.79	0.237 10.79	0.281 12.66	0.337 14.98	0.337 14.98	0.438 19.01			0.531 22.51	0.674 27.54
4-1/2	5.000							0.247 12.53			0.355 17.61						0.710 32.53
5	5.563	0.109 6.349	0.109 6.349	0.134 7.770	0.134 7.770			0.238 14.62	0.258 14.62		0.375 20.78	0.375 20.78	0.500 27.04			0.625 32.96	0.750 38.55
6	6.625	0.109 7.585	0.109 7.585	0.134 9.290	0.134 9.289			0.290 18.97	0.290 18.97		0.432 28.57	0.432 28.57	0.562 36.39			0.719 45.30	0.864 43.16
7	7.625							0.301 23.57			0.500 38.05						0.875 63.08
8	8.625	0.109 9.914	0.109 9.914	0.148 13.40	0.148 13.40	0.250 22.36	0.277 24.70	0.322 28.55	0.322 28.55	0.406 35.64	0.500 43.39	0.500 43.39	0.594 50.87	0.719 60.93	0.812 67.76	0.906 74.69	0.875 72.42
9	9.625							0.342 33.90			0.500 48.72						
10	10.750	0.134 15.19	0.134 15.19	0.165 18.65	0.165 18.70	0.250 28.04	0.307 34.24	0.365 40.48	0.365 40.48	0.500 54.74	0.500 54.74	0.594 64.33	0.719 76.92	0.844 89.20	1.000 104.1	1.125 115.7	
11	11.750							0.375 45.55			0.500 60.07						
12	12.750	0.156 21.07	0.165 22.18	0.180 24.16	0.180 24.20	0.250 33.38	0.330 43.77	0.375 49.56	0.406 53.33	0.562 73.16	0.500 65.42	0.688 88.51	0.844 107.2	1.000 125.5	1.125 139.7	1.312 160.3	
14	14.000	0.156 23.07		0.188 27.73	0.250 36.71	0.312 45.68	0.375 54.57	0.375 54.57	0.438 63.37	0.594 84.91	0.500 72.09	0.750 106.1	0.938 130.7	1.094 150.7	1.250 170.2	1.406 189.1	
16	16.000	0.165 27.90		0.188 31.75	0.250 42.06	0.312 52.36	0.375 62.58	0.375 62.58	0.500 82.77	0.656 107.5	0.500 82.77	0.844 136.5	1.031 164.8	0.129 192.3	1.438 223.5	1.594 245.1	
18	18.000	0.165 31.43		0.188 35.76	0.250 47.39	0.312 59.03	0.438 82.06	0.375 70.59	0.562 104.8	0.750 138.2	0.500 93.45	0.938 170.8	1.156 208.0	1.375 244.1	1.562 274.2	1.781 308.5	
20	20.000	0.188 38.78		0.218 46.06	0.250 52.73	0.375 78.60	0.500 104.1	0.375 78.60	0.594 122.9	0.812 166.4	0.500 104.1	1.031 208.9	1.281 256.1	1.500 296.4	1.750 341.1	1.988 379.0	
24	24.000	0.218 55.37		0.250 63.41	0.250 63.41	0.375 94.62	0.562 140.8	0.375 94.62	0.688 171.2	0.969 238.1	0.500 125.5	1.219 296.4	1.531 367.4	1.812 429.4	2.062 483.1	2.343 541.9	
UPPER FIGURES Wall Thickness in inches		DIMENSIONS AND WEIGHTS OF SEAMLESS AND WELDED STEEL PIPE														LOWER FIGURES Weight per foot in pounds	

附录 IV 管材公称等级

管材 尺寸	外径 (英寸)	5s	5	10s	10	20	30	40s Std	40	60	80s 和 E.H.	80	100	120	140	160	双 E.H.
1/8	0.405		0.035 0.1383	0.049 0.1863	0.049 0.1863			0.068 0.2447	0.068 0.2447		0.095 0.3145	0.095 0.3145					
1/4	0.540		0.049 0.2570	0.065 0.3297	0.065 0.3297			0.088 0.4248	0.088 0.4248		0.119 0.5351	0.119 0.5351					
3/8	0.675		0.049 0.3276	0.065 0.4235	0.065 0.4235			0.091 0.5676	0.091 0.5676		0.126 0.7388	0.126 0.7388					
1/2	0.840	0.065 0.5383	0.065 0.5383	0.083 0.6710	0.083 0.6710			0.109 0.8510	0.109 0.8510		0.147 1.088	0.147 1.088				0.188 1.304	0.294 1.714
3/4	1.050	0.065 0.6838	0.065 0.6838	0.083 0.8572	0.083 0.8572			0.113 1.131	0.113 1.131		0.154 1.474	0.154 1.474				0.219 1.937	0.308 2.441
1	1.315	0.065 0.8678	0.065 0.8678	0.109 1.404	0.109 1.404			0.113 1.679	0.113 1.679		0.179 2.172	0.179 2.172				0.250 2.844	0.358 3.659
1-1/4	1.660	0.065 1.107	0.065 1.107	0.109 1.806	0.109 1.806			0.140 2.273	0.140 2.273		0.191 2.997	0.191 2.997				0.250 3.765	0.382 5.214
1-1/2	1.900	0.065 1.274	0.065 1.274	0.109 2.085	0.109 2.085			0.145 2.718	0.145 2.718		0.200 3.631	0.200 3.631				0.281 4.859	0.400 6.408
2	2.375	0.065 1.604	0.065 1.604	0.109 2.638	0.109 2.638			0.154 3.653	0.154 3.653		0.218 5.022	0.218 5.022				0.344 7.444	0.436 9.029
2-1/2	2.875	0.083 2.475	0.083 2.475	0.120 3.531	0.120 3.531			0.203 5.793	0.203 5.793		0.276 7.661	0.276 7.661				0.375 10.01	0.552 13.70
3	3.500	0.083 3.029	0.083 3.029	0.120 4.332	0.120 4.332			0.216 7.576	0.216 7.576		0.300 10.25	0.300 10.25				0.438 14.32	0.600 18.58
3-1/2	4.000	0.083 3.472	0.083 3.472	0.120 4.973	0.120 4.973			0.226 9.109	0.226 9.109		0.318 12.51	0.318 12.51					0.636 22.85
4	4.500	0.083 3.915	0.083 3.915	0.120 5.613	0.120 5.613			0.237 10.79	0.237 10.79	0.281 12.66	0.337 14.98	0.337 14.98		0.438 19.01		0.531 22.51	0.674 27.54
4-1/2	5.000							0.247 12.53			0.355 17.61						0.710 32.53
5	5.563	0.109 6.349	0.109 6.349	0.134 7.770	0.134 7.770			0.238 14.62	0.238 14.62		0.375 20.78	0.375 20.78		0.500 27.04		0.625 32.96	0.750 38.55
6	6.625	0.109 7.585	0.109 7.585	0.134 9.290	0.134 9.290			0.280 18.97	0.280 18.97		0.432 28.57	0.432 28.57		0.562 36.39		0.719 45.30	0.864 43.16
7	7.625							0.301 23.57			0.500 38.05						0.875 63.08
8	8.625	0.109 9.914	0.109 9.914	0.148 13.40	0.148 13.40	0.250 22.36	0.277 24.70	0.322 28.55	0.322 28.55	0.406 35.64	0.500 43.39	0.500 43.39	0.594 50.87	0.719 60.93	0.812 67.76	0.960 74.69	0.875 72.42
9	9.625							0.342 33.90			0.500 48.72						
10	10.750	0.134 15.19	0.134 15.19	0.165 18.65	0.165 18.65	0.250 28.04	0.307 34.24	0.365 40.48	0.365 40.48	0.500 54.74	0.500 54.74	0.594 64.33	0.719 76.93	0.844 89.20	1.000 104.1	1.125 115.7	
11	11.750							0.375 45.55			0.500 60.07						
12	12.750	0.156 21.07	0.165 22.18	0.180 24.16	0.180 24.16	0.250 33.38	0.330 43.77	0.375 49.56	0.375 49.56	0.562 73.16	0.500 65.42	0.688 88.51	0.844 107.2	1.000 125.5	1.125 139.7	1.312 160.3	
14	14.000	0.156 23.07		0.188 27.73	0.250 36.71	0.312 45.68	0.375 54.57	0.375 54.57	0.438 63.37	0.594 84.91	0.500 72.09	0.750 106.1	0.938 130.7	1.094 150.7	1.250 170.2	1.406 189.1	
16	16.000	0.165 27.90		0.188 31.75	0.250 42.05	0.312 52.36	0.375 62.58	0.375 62.58	0.500 82.77	0.656 107.5	0.500 82.77	0.844 136.5	1.031 164.8	1.129 192.3	1.438 223.5	1.594 245.1	
18	18.000	0.165 31.43		0.188 35.76	0.250 47.39	0.312 59.03	0.438 82.06	0.375 70.59	0.562 104.8	0.750 138.2	0.500 93.45	0.938 170.8	1.156 208.0	1.375 244.1	1.562 274.2	1.781 308.5	
20	20.000	0.188 39.78		0.218 46.05	0.250 52.73	0.375 78.60	0.500 104.1	0.375 78.60	0.594 122.9	0.812 166.4	0.500 104.1	1.031 208.9	1.281 256.1	1.500 296.4	1.750 341.1	1.969 379.0	
24	24.000	0.218 55.37		0.250 63.41	0.250 63.41	0.375 94.62	0.562 140.8	0.375 94.62	0.688 171.2	0.969 238.1	0.500 125.5	1.219 296.4	1.531 367.4	1.812 429.4	2.062 483.1	2.343 541.9	
上部数据 壁厚 英寸		无缝管和焊管的 尺寸和重量														下部数据 重量 磅/英尺	

APPENDIX V

ACCEPTABLE AND UNACCEPTABLE WELD PROFILES

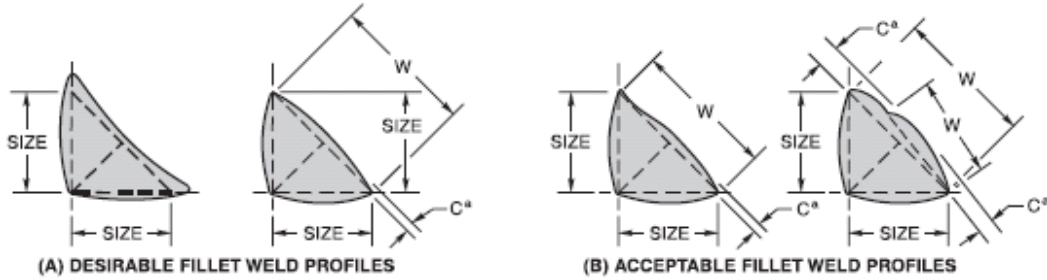

*Convexity, C, of a weld or individual surface bead with dimension W shall not exceed the value of the following table:

WIDTH OF WELD FACE OR INDIVIDUAL SURFACE BEAD, W	MAX. CONVEXITY, C
$W \leq 5/16$ in	1/16 in
$W > 5/16$ in TO $W < 1$ in	1/8 in
$W \geq 1$ in	3/16 in

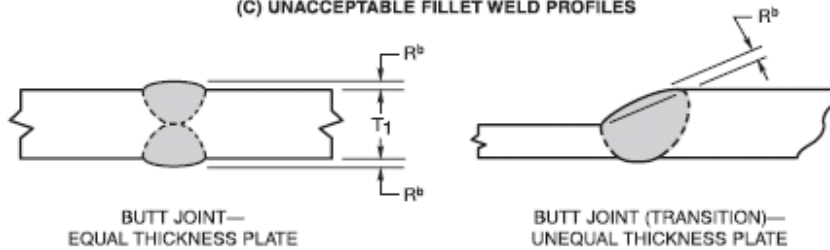
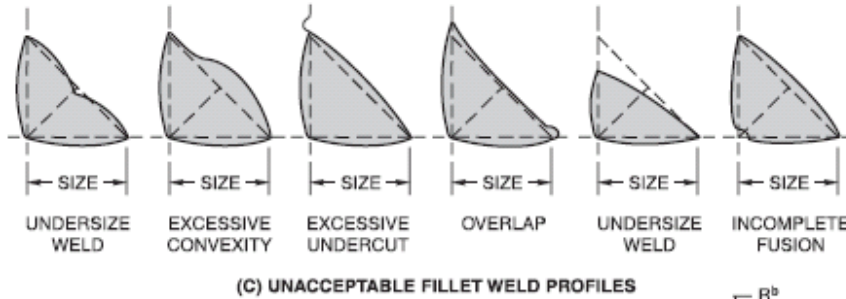

^bReinforcement R shall not exceed 1/8 in.

(D) ACCEPTABLE GROOVE WELD PROFILE IN BUTT JOINT

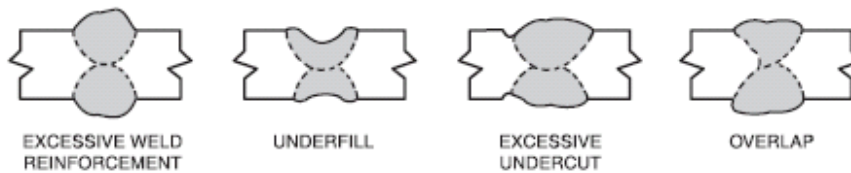

(E) UNACCEPTABLE GROOVE WELD PROFILES IN BUTT JOINTS

附录 V

合格和不合格的焊缝外形

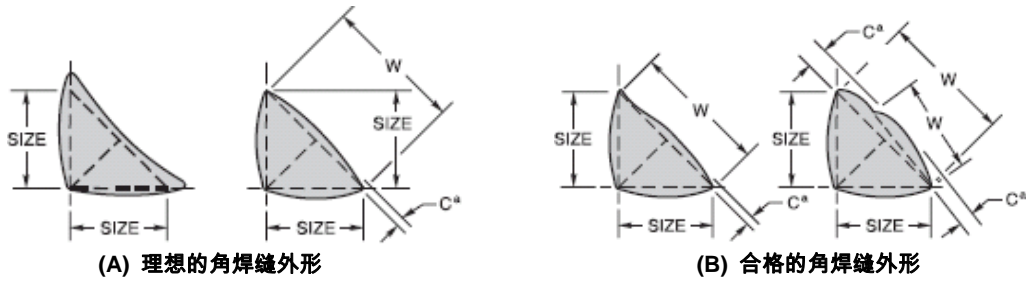

(A) 理想的角焊缝外形

(B) 合格的角焊缝外形

^a 宽度为 W 的焊缝或单个表面焊道的凸度 C 不得超过下表规定的数值:

焊缝或单个表面焊道的宽度, W	最大凸度, C
$W \leq 5/16$ 英寸	1/16 英寸
$5/16$ 英寸 $< W < 1$ 英寸	1/8 英寸
$W \geq 1$ 英寸	3/16 英寸

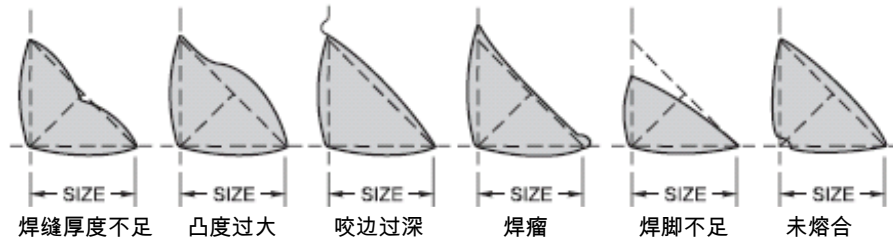

(C) 不合格的角焊缝外形

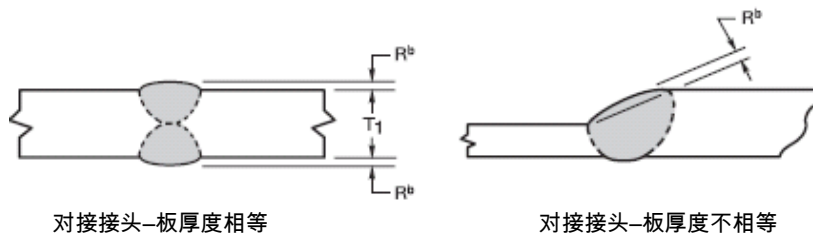

对接接头-板厚度相等

对接接头-板厚度不相等

^b 余高 R 不得超过 1/8 英寸

(D) 对接接头的合格坡口焊缝外形

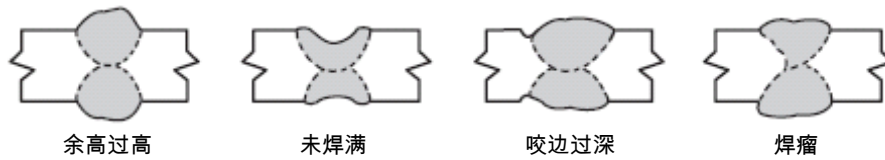

余高过高

未焊满

咬边过深

焊瘤

(E) 对接接头的不合格坡口焊缝外形

APPENDIX VI WELD PROFILE ACCEPTANCE DESCRIPTION

- (1) The faces of fillet welds may be slightly convex, flat, or slightly concave as shown in Appendix V (A) and (B), with none of the unacceptable profiles shown in (C). Except at outside corner joints, the convexity, C, of a weld or individual surface bead with dimension W shall not exceed the values noted in the table in Appendix V.
- (2) Groove welds shall preferably be made with slight or minimum reinforcement except as may be otherwise provided. In the case of butt and corner joints, the reinforcement shall not exceed 1/8 in [3.2 mm] in height and shall have gradual transition to the plane of the base metal surface. See Appendix V. They shall be free of the discontinuities shown for butt joints in (E).
- (3) Surfaces of groove welds required to be flush shall be finished so as not to reduce the thickness of the thinner base metal or weld metal by more than 1/32 in [0.8 mm] or 5% of the thickness, whichever is smaller, nor leave reinforcement that exceeds 1/32 in [0.8 mm]. However, all reinforcement must be removed where the weld forms part of a faying or contact surface. Any reinforcement must blend smoothly into the plate surfaces with transition areas free from weld undercut. Chipping may be used provided it is followed by grinding. Where surface finishing is required, its roughness value shall not exceed 250 μin [6.3 μm]. Surfaces finished to values of over 125 μin [3.2 μm] through 250 μin [6.3 μm] shall be finished so that the grinding marks are parallel to the direction of primary stress. Surfaces finished to values of 125 μin [3.2 μm] or less may be finished in any direction.
- (4) Ends of groove welds required to be flush shall be finished so as not to reduce the width beyond the detailed width or the actual width furnished, whichever is greater, by more than 1/8 in [3.2 mm] or so as not to leave reinforcement at each end that exceeds 1/8 in [3.2 mm]. Ends of welds in butt joints shall be faired to adjacent plate or shape edges at a slope not to exceed 1 in 10.
- (5) Welds shall be free from overlap.

附录 VI 合格焊缝外形的描述

- (1) 角焊缝表面可以是附录 V (A)和(B)所示的微凸, 平或微凹, 不允许有(C)所示的不合格焊缝外形。除在外侧的角接头外, 宽度为 W 的焊缝或单个表面焊道的凸度 C 不得超过附录 V 表中规定的数值。
- (2) 除另有要求外, 坡口焊缝应略有余高或有最小的余高。对于对接和角接头, 余高不能超过 1/8 英寸[3.2 mm], 并且应和母材表面平滑过渡, 不应有(E)所示的对接接头的 discontinuity。参见附录 V。
- (3) 对于表面需磨平的坡口焊缝, 打磨后的厚度减少不应超过 1/32 英寸[0.8 mm]或较薄母材或焊缝金属厚度的 5%(两者取较小值), 也不应使留下的余高超过 1/32 英寸[0.8 mm], 但结合面或接触面的焊缝余高必须全部去除。任何余高必须和母材表面平滑过渡, 并且在过渡区域内没有咬边。可以采用先铲凿后打磨的方法。对表面光洁度有要求的焊缝, 粗糙度不应超过 250 μin [6.3 μm]。表面光洁度在 125 μin [3.2 μm]和 250 μin [6.3 μm]之间时, 磨痕必须平行于主应力的方向。表面光洁度小于等于 125 μin [3.2 μm]时, 对磨痕的方向没有要求。
- (4) 对于端部需磨平的坡口焊缝, 打磨后的焊缝宽度不应使图示宽度或实际宽度(两者取较大值)减少超过 1/8 英寸[3.2 mm], 也不应使留下的余高超过 1/8 英寸[3.2 mm]。和板或型材边缘相接的对接接头端部应是不超过 1:10 的斜面过渡。
- (5) 焊缝不允许有焊瘤。

APPENDIX VII

VISUAL WELD INSPECTION ACCEPTANCE CRITERIA

Slag shall be removed from all completed welds. All welds and the adjacent base metal shall be cleaned by brushing or by any other suitable means prior to visual inspection. All welds shall meet the following visual acceptance criteria prior to any nondestructive or destructive testing. To be visually acceptable, a weld shall meet the following criteria:

- (1) The weld shall have no cracks.
- (2) Thorough fusion shall exist between adjacent layers of weld metal and between weld metal and base metal.
- (3) All craters shall be filled to the full cross section of the weld.
- (4) Weld profiles shall be in accordance with Appendices V and VI.
- (5) When the weld is transverse to the primary tensile stress in the part that is undercut, the undercut shall be no more than 0.010 in [0.25 mm] deep.
- (6) When the weld is parallel to the primary tensile stress in the part that is undercut, the undercut shall be no more than 1/32 in [0.80 mm] deep.
- (7) The sum of the diameters of visible porosity shall not exceed 3/8 in [9.5 mm] in any linear inch of weld nor shall the sum exceed 3/4 in [19.0 mm] in any 12 in [305 mm] length of weld.
- (8) Any single continuous fillet weld shall be permitted to underrun the nominal fillet weld size specified by 1/16 in [1.6 mm].
- (9) Visual inspections of welds in all steels may begin immediately after the completed welds have cooled to ambient temperature. Final visual inspection for ASTM A 514 and A 517 steel welds shall be performed not less than 48 hours after completion of the weld and removal of preheat.
- (10) Arc strikes outside the weld groove or area are prohibited.

附录 VII

焊缝目视检验的验收标准

完工焊缝必须清除焊渣。目视检验前，所有焊缝和相邻母材必须用刷子刷或用其他合适的方法清理干净。在任何无损探伤或破坏性试验之前，所有焊缝必须满足下列目视检验的验收标准。目视检验合格的焊缝必须符合以下标准：

- (1) 焊缝无裂纹。
- (2) 焊道之间及焊缝金属与母材之间必须完全熔合。
- (3) 所有弧坑必须填至整个焊缝截面。
- (4) 焊缝外形符合附录 V 和 VI。
- (5) 当焊缝垂直于主拉应力时，咬边深度不可超过 0.010 in [0.25 mm]。
- (6) 当焊缝平行于主拉应力时，咬边深度不可超过 1/32 in [0.8 mm]。
- (7) 在任何 1 英寸的焊缝内，可见气孔直径之和不可超过 3/8 in [9.5 mm]，并且在任何 12 in [305 mm] 长的焊缝内，可见气孔直径之和不可超过 3/4 in [19.0 mm]。
- (8) 任何单道连续角焊缝允许比规定的角焊缝尺寸小 1/16 in [1.6 mm]。
- (9) 对于任何钢材，完工焊缝冷却至环境温度后即可立即进行目视检验。对 ASTM A514 和 A517 材料的焊缝，最终目视检验必须在焊缝完工和去除预热 48 小时后进行。
- (10) 禁止在焊缝坡口和焊接区域之外有电弧击伤。

APPENDIX VIII TEST RESULTS REQUIRED, GUIDED BENDS

All Guided Bend Tests. The convex surface of the bend test specimen shall be visually examined for surface discontinuities. For acceptance, the surface shall meet the following criteria:

- (1) No single discontinuity shall exceed 1/8 in [3.2 mm] measured in any direction.
- (2) The sum of the greatest dimensions of all discontinuities exceeding 1/32 in [0.8 mm] but less than or equal to 1/8 in [3.2 mm] shall not exceed 3/8 in [9.5 mm].
- (3) Corner cracks shall not exceed 1/4 in [6.4 mm] unless the crack results from a visible slag inclusion or other fusion type discontinuity, then the 1/8 in [3.2 mm] maximum shall apply.

The specimens with corner cracks exceeding 1/4 in [6.4 mm] with no evidence of slag inclusions or other fusion type discontinuities shall be disregarded, and a replacement test specimen from the original weldment shall be tested.

附录 VIII 导向弯曲试验验收要求

所有的导向弯曲试验。 应对弯曲试样的外凸表面的不连续进行目视检验。合格试样的表面必须符合下列验收标准:

- (1) 在任何方向上, 任何单个不连续的长度不能超过 1/8 in [3.2 mm].
- (2) 所有大于 1/32 in [0.8 mm]但小于等于 1/8 in [3.2 mm]的不连续的最大尺寸之和不能超过 3/8 in [9.5 mm].
- (3) 角部裂纹不能超过 1/4 in [6.4 mm]. 但如果角部裂纹是由可见夹渣或其他熔合性不连续所致, 则角部裂纹最大不能超过 1/8 in [3.2 mm].

角部裂纹超过 1/4 in [6.4 mm]但无可见夹渣或其他熔合性不连续的试样应舍弃, 并应从原焊接件上另取试样进行试验.

APPENDIX IX

WELD METAL ANALYSIS

A-NUMBERS Classification of Ferrous Weld Metal Analysis for Procedure Qualification

A-No.	Types of Weld Deposit	Analysis, % ^a					
		C	Cr	Mo	Ni	Mn	Si
1	Mild Steel	0.15	—	—	—	1.60	1.00
2	Carbon–Molybdenum	0.15	0.50	0.40–0.65	—	1.60	1.00
3	Chrome (0.4% to 2%)–Molybdenum	0.15	0.40–2.00	0.40–0.65	—	1.60	1.00
4	Chrome (2% to 6%)–Molybdenum	0.15	2.00–6.00	0.40–1.50	—	1.60	2.00
5	Chrome (6% to 10.5%)–Molybdenum	0.15	6.00–10.50	0.40–1.50	—	1.20	2.00
6	Chrome–Martensitic	0.15	11.00–15.00	0.70	—	2.00	1.00
7	Chrome–Ferritic	0.15	11.00–30.00	1.00	—	1.00	3.00
8	Chromium–Nickel	0.15	14.50–30.00	4.00	7.50–15.00	2.50	1.00
9	Chromium–Nickel	0.30	25.00–30.00	4.00	15.00–37.00	2.50	1.00
10	Nickel to 4%	0.15	—	0.55	0.80–4.00	1.70	1.00
11	Manganese–Molybdenum	0.17	—	0.25–0.75	0.85	1.25–2.25	1.00
12	Nickel–Chrome–Molybdenum	0.15	1.50	0.25–0.80	1.25–2.80	0.75–2.25	1.00

^aSingle values shown above are maximum.

附录 IX

焊缝金属分析

A-号

用于焊接工艺评定的铁基焊缝金属化学成分分类

A-号	熔敷金属类型	化学成分, % ^a					
		C	Cr	Mo	Ni	Mn	Si
1	低碳钢	0.15	-	-	-	1.60	1.00
2	碳–钼	0.15	0.50	0.40-0.65	-	1.60	1.00
3	铬(0.4% - 2%)–钼	0.15	0.40-2.00	0.40-0.65	-	1.60	1.00
4	铬(2% - 6%)–钼	0.15	2.00-6.00	0.40-1.50	-	1.60	2.00
5	铬(6% - 10.5%)–钼	0.15	6.00-10.50	0.40-1.50	-	1.20	2.00
6	铬–马氏体	0.15	11.00-15.00	0.70	-	2.00	1.00
7	铬–铁素体	0.15	11.00-30.00	1.00	-	1.00	3.00
8	铬–镍	0.15	14.50-30.00	4.00	7.50-15.00	2.50	1.00
9	铬–镍	0.30	25.00-30.00	4.00	15.00-37.00	2.50	1.00
10	镍 小于等于 4%	0.15	-	0.55	0.80-4.00	1.70	1.00
11	锰–钼	0.17	-	0.25-0.75	0.85	1.25-2.25	1.00
12	镍–铬–钼	0.15	1.50	0.25-0.80	1.25-2.80	0.75-2.25	1.00

^a 上表中单个数值为最大值。

APPENDIX X

ELECTRODE GROUPS

F-NUMBERS Grouping of Electrodes and Welding Rods for Qualification

F-No.	AWS Specification	AWS Classification
Steel		
1	A5.1	EXX20, EXX22, EXX24, EXX27, EXX28
1	A5.4	EXXX(X)-25, EXXX(X)-26
1	A5.5	EXX20-XX, EXX27-XX
2	A5.1	EXX12, EXX13, EXX14, EXX19
2	A5.5	E(X)XX19-XX
3	A5.1	EXX10, EXX11
3	A5.5	E(X)XX10-XX, E(X)XX11-XX
4	A5.1	EXX15, EXX16, EXX18, EXX18M, EXX48
4	A5.4 other than austenitic and duplex	EXXX(X)-15, EXXX(X)-16, EXXX(X)-17
4	A5.5	E(X)XX15-XX, E(X)XX16-XX, E(X)XX18-XX, E(X)XX18M, E(X)XX18M1
5	A5.4 austenitic and duplex	EXXX(X)-15, EXXX(X)-16, EXXX(X)-17
6	A5.2	RX
6	A5.9	ERXXX(XXX), ECXXX(XXX), EQXXX(XXX)
6	A5.17	FXXX-EXX, FXXX-ECX
6	A5.18	ERXXS-X, EXXC-X, EXXC-XX
6	A5.20	EXXT-X, EXXT-XM
6	A5.22	EXXTX-X, RXXXT1-5
6	A5.23	FXXX-EXXX-X, FXXX-ECXXX-X
6	A5.23	FXXX-EXXX-XN, FXXX-ECXXX-XN
6	A5.25	FESXX-EXXX, FESXX-EWXX
6	A5.26	EGXXS-X, EGXXT-X
6	A5.28	ERXXS-XXX, EXXC-XXX
6	A5.29	EXXTX-X
6	A5.30	INXXX
Aluminum and Aluminum Alloys		
21	A5.3	E1100, E3003
21	A5.10	ER1100, R1100, ER1188, R1188
22	A5.10	ER5183, R5183, ER5356, R5356, ER5554, R5554, ER5556, R5556, ER5654, R5654
23	A5.3	E4043
23	A5.10	ER4009, R4009, ER4010, R4011, R4010, ER4043, R4043, ER4047, R4047, ER4145, R4145, ER4643, R4643
24	A5.10	R206.0, R-C355.0, R-A356.0, R357.0, R-A357.0
25	A5.10	ER2319, R2319

附录 X 焊材分组

F-号 评定用焊条和焊丝分组

F-号	AWS 技术规范	AWS 类别
钢		
1	A5.1	EXX20, EXX22, EXX24, EXX27, EXX28
1	A5.4	EXXX(X)-25, EXXX(X)-26
1	A5.5	EXX20-XX, EXX27-XX
2	A5.1	EXX12, EXX13, EXX14, EXX19
2	A5.5	E(X)XX13-XX
3	A5.1	EXX10, EXX11
3	A5.5	E(X)XX10-XX, E(X)XX11-XX
4	A5.1	EXX15, EXX16, EXX18, EXX18M, EXX48
4	A5.4 除奥氏体和双相	EXXX(X)-15, EXXX(X)-16, EXXX(X)-17
4	A5.5	E(X)XX15-XX, E(X)XX16-XX, E(X)XX18-XX, E(X)XX18M, E(X)XX18M1
5	A5.4 奥氏体和双相	EXXX(X)-15, EXXX(X)-16, EXXX(X)-17
6	A5.2	RX
6	A5.9	ERXXX(XXX), ECXXX(XXX), EQXXX(XXX)
6	A5.17	FXXX-EXX, FXXX-ECX
6	A5.18	ERXXS-X, EXXC-X, EXXC-XX
6	A5.20	EXXT-X, EXXT-XM
6	A5.22	EXXTX-X, RXXXT1-5
6	A5.23	FXXX-EXXX-X, FXXX-ECXXX-X
6	A5.23	FXXX-EXXX-XN, FXXX-ECXXX-XN
6	A5.25	FESXX-EXXX, FESXX-EWXX
6	A5.26	EGXXS-X, EGXXT-X
6	A5.28	ERXXS-XXX, EXXC-XXX
6	A5.29	EXXTX-X
6	A5.30	INXXX
铝及铝合金		
21	A5.3	E1100, E3003
21	A5.10	ER1100, R1100, ER1188, R1188
22	A5.10	ER5183, R5183, ER5356, R5356, ER5554, R5554, ER5556, R5556, ER5654, R5654
23	A5.3	E4043
23	A5.10	ER4009, R4009, ER4010, R4011, R4010, ER4043, R4043, ER4047, R4047, ER4145, R4145, ER4643, R4643
24	A5.10	R206.0, R-C355.0, R-A356.0, R357.0, R-A357.0
25	A5.10	ER2319, R2319

APPENDIX X (Continued)

ELECTRODE GROUPS

F-NUMBERS Grouping of Electrodes and Welding Rods for Qualification

F-No.	AWS Specification	AWS Classification
Copper and Copper Alloys		
31	A5.6 and A5.7	RCu, ECu
32	A5.6	ECuSi and ERCuSi-A
33	A5.6 and A5.7	ECuSn-A, ECuSn-C, ERCuSn-A
34	A5.6, A5.7, and A5.30	ECuNi, ERCuNi, IN67
35	A5.8	RBCuZn-A, RBCuZn-B, RCuZn-C, RBCuZn-D
36	A5.6 and A5.7	ERCuAl-A1, ERCuAl-A2, ERCuAl-A3, ECuAl-A2, ECuAl-B
37	A5.6 and A5.7	RCuNiAl, ECuMnNiAl, ERCuNiAl, ERCuMnNiAl
Nickel and Nickel Alloys		
41	A5.11, A5.14, and A5.30	ENi-1, ERNi-1, IN61
42	A5.11, A5.14, and A5.30	ENiCu-7, ERNiCu-7, ERNiCu-8, IN60
43	A5.11	ENiCrFe-1, 2, 3, 4, 7, 9, and 10; ENiCrMo-2, 3, 6, and 12; ENiCrCoMo-1
43	A5.14	ERNiCr-3, 4, and 6; ERNiCrFe-5, 6, 7, 8, and 11; ERNiCrCoMo-1; ERNiCrMo-2 and 3
43	A5.30	IN6A, IN62, IN82
44	A5.11	ENiMo-1, 3, 7, 8, 9, and 10; ENiCrMo-4, 5, 7, 10, 13, and 14
44	A5.14	ERNiMo-1, 2, 3, 7 (B2), 8, 9, and 10; ERNiCrMo-4, 7 (alloy C4), 10, 13, 14; ERNiCrWMo-1
45	A5.11	ENiCrMo-1, 9, and 11
45	A5.14	ERNiCrMo-1, 8, 9, and 11; ERNiFeCr-1
Titanium and Titanium Alloys		
51	A5.16	ERTi-1, ERTi-2, ERTi-3, ERTi-4
52	A5.16	ERTi-7
53	A5.16	ERTi-9, ERTi-9ELI
54	A5.16	ERTi-12
55	A5.16	ERTi-5, ERTi-5ELI, ERTi-6, ERTi-6ELI, ERTi-15
Zirconium and Zirconium Alloys		
61	A5.24	ERZr2, ERZr3, ERZr4
Hardfacing Weld Metal Overlay		
71	A5.13 and A5.21	RXXX-X, EXXX-X
Magnesium Alloys		
91	A5.19	ER AZ61A, ER AZ92A, ER EZ33A, ER AZ101A, R AZ61A, R AZ92A, R AZ101A, R EZ33A

附录 X (续)

焊材分组

F-号

评定用焊条和焊丝分组

F-号	AWS 技术规范	AWS 类别
铜及铜合金		
31	A5.6 和 A5.7	RCu, ECu
32	A5.6	ECuSi and ERCuSi-A
33	A5.6 和 A5.7	ECuSn-A, ECuSn-C, ERCuSn-A
34	A5.6, A5.7 和 A5.30	ECuNi, ERCuNi, IN67
35	A5.8	RBCuZn-A, RBCuZn-B, RCuZn-C, RBCuZn-D
36	A5.6 和 A5.7	ERCuAl-A1, ERCuAl-A2, ERCuAl-A3, ECuAl-A2, ECuAl-B
37	A5.6 和 A5.7	RCuNiAl, ECuMnNiAl, ERCuNiAl, ERCuMnNiAl
镍及镍合金		
41	A5.11, A5.14 和 A5.30	ENi-1, ERNi-1, IN61
42	A5.11, A5.14 和 A5.30	ENiCu-7, ERNiCu-7, ERNiCu-8, IN60
43	A5.11	ENiCrFe-1, 2, 3, 4, 7, 9, and 10; ENiCrMo-2, 3, 6, and 12; ENiCrCoMo-1
43	A5.14	ERNiCr-3, 4, and 6; ERNiCrFe-5, 6, 7, 8, and 11; ERNiCrCoMo-1; ERNiCrMo-2 and 3
43	A5.30	IN6A, IN62, IN82
44	A5.11	ENiMo-1, 3, 7, 8, 9, and 10; ENiCrMo-4, 5, 7, 10, 13, and 14
44	A5.14	ERNiMo-1, 2, 3, 7 (B2), 8, 9, and 10; ERNiCrMo-4, 7 (C4 合金), 10, 13, 14; ERNiCrWMo-1
45	A5.11	ENiCrMo-1, 9, and 11
46	A5.14	ERNiCrMo-1, 8, 9, and 11; ERNiFeCr-1
钛及钛合金		
51	A5.16	ERTi-1, ERTi-2, ERTi-3, ERTi-4
52	A5.16	ERTi-7
53	A5.16	ERTi-9, ERTi-9ELI
54	A5.16	ERTi-12
55	A5.16	ERTi-5, ERTi-5ELI, ERTi-6, ERTi-6ELI, ERTi-15
锆及锆合金		
61	A5.24	ERZr2, ERZr3, ERZr4
耐磨层堆焊		
71	A5.13 和 A5.21	RXXX-X, EXXX-X
镁合金		
91	A5.19	ER AZ61A, ER AZ92A, ER EZ33A, ER AZ101A, R AZ61A, R AZ92A, R AZ101A, R EZ33A

APPENDIX XI

WELDER QUALIFICATION TEST REQUIREMENTS

1. Tests on plate									
Type of Weld	Thickness of Test Plate (T) As Welded, in	Visual Inspection	Number of Specimens				T-Joint Break	Macroetch Test	Plate Thickness Qualified, in
			Bend Tests						
			Face	Root	Side				
Groove	3/8	Yes	1	1	—	—	—	3/4 max. ^a	
Groove	3/8 < T < 1	Yes	—	—	2	—	—	1/8–2T ^a	
Groove	1 or over	Yes	—	—	2	—	—	Unlimited ^a	
Fillet Option No. 1	1/2	Yes	—	—	—	1	1	Unlimited	
Fillet Option No. 2	3/8	Yes	—	2	—	—	—	Unlimited	

^aAlso qualifies for welding fillet welds on material of unlimited thickness.

2. Tests on pipe or tubing												
Type of Weld	Pipe or Tubing Size, As Welded		Visual Inspection	Number of Specimens						Pipe or Tube Size Qualified, in	Plate, Pipe, or Tube Wall Thickness Qualified, in	
	Diam	Nominal Thickness		All Positions Except 5G and 6G			5G and 6G Positions Only				Min.	Max. ^a
				Face Bend	Root Bend	Side Bend	Face Bend	Root Bend	Side Bend			
Groove	2 in or 3 in	Sch. 80 Sch. 40	Yes	1	1	—	2	2	—	4 or smaller	1/8	3/4 ^a
Groove	6 in or 8 in	Sch. 120 Sch. 80	Yes	—	—	2	—	—	4	4 or larger	3/16	Unlimited ^a

^aAlso qualifies for welding fillet welds on material of unlimited thickness.

附录 XI

焊工评定试验要求

1. 板材试验								
焊缝类型	焊接试板 厚度(T) in.	目视 检验	试样数量				宏观试验	评定的板材 厚度范围 in.
			弯曲试验			T 型接头 折断试验		
			面弯	背弯	侧弯			
坡口焊缝	3/8	要	1	1	-	-	-	最厚 3/4 ^a
坡口焊缝	3/8<T<1	要	-	-	2	-	-	1/8-2T ^a
坡口焊缝	≥1	要	-	-	2	-	-	无限制 ^a
角焊缝选择#1	1/2	要	-	-	-	1	1	无限制
角焊缝选择#2	3/8	要	-	2	-	-	-	无限制

^a 也覆盖了所有厚度的角焊缝。

2. 管材试验												
焊缝类型	焊接试管尺寸		目视 检验	试样数量						评定的 管材 尺寸 in.	评定的板材,管材 厚度 in.	
	直径	公称壁厚		除 5G 和 6G 外的 所有位置			仅 5G 和 6G 位置				最小	最大 ^a
				面 弯	背 弯	侧 弯	面 弯	背 弯	侧 弯			
坡口焊缝	2 in. 或 3 in.	Sch. 80 Sch. 40	要	1	1	-	2	2	-	≤4	1/8	3/4 ^a
坡口焊缝	6 in. 或 8 in.	Sch. 120 Sch. 80	要	-	-	2	-	-	4	≥4	3/16	无限制 ^a

^a 也覆盖了所有厚度的角焊缝。

APPENDIX XI (Continued)

Welder Qualification—Type and Position Limitations

Qualification Test		Type of Weld and Position of Welding Qualified			
		Plate		Pipe	
Weld	Plate or Pipe Positions	Groove	Fillet	Groove	Fillet
Plate-Groove	1G 2G 3G 4G 3G and 4G	F F, H F, H, V F, OH All	F, H F, H F, H, V F, H, OH All	F ^a F, H ^a F, H, V ^a	F, H F, H F, H F F, H
Plate-Fillet ^b	1F 2F 3F 4F 3F and 4F		F F, H F, H, V F, H, OH All		F F, H F, H, V F, H, OH All
Pipe-Groove	1G 2G 5G 6G 2G and 5G 6GR	F F, H F, V, OH Note c Note c All	F, H F, H F, V, OH Note c Note c All	F F, H F, V, OH Note c Note c All	F, H F, H F, V, OH Note c Note c All
Pipe-Fillet	1F 2F 2F Rolled 4F 4F and 5F		F F, H F, H F, H, OH All		F F, H F, H F, H, OH All

^aWelders qualified to weld tubulars over 24 in [600 mm] in diameter with backing or backgouging, for the test position indicated.

^bNot applicable for fillet welds between parts having a dihedral angle (ψ) of 60° or less.

^cQualified for all except groove welds for T-, Y-, and K-connections.

附录 XI (续)

焊工评定—类型和位置的限制

评定试验		焊缝类型和焊接位置的评定范围			
		板材		管材	
焊缝	板或管位置	坡口焊缝	角焊缝	坡口焊缝	角焊缝
板-坡口焊缝	1G	F	F, H	F ^a	F, H
	2G	F, H	F, H	F, H ^a	F, H
	3G	F, H, V	F, H, V	F, H, V ^a	F, H
	4G	F, OH	F, H, OH		F
	3G 和 4G	所有	所有		F, H
板-角焊缝 ^b	1F		F		F
	2F		F, H		F, H
	3F		F, H, V		F, H, V
	4F		F, H, OH		F, H, OH
	3F 和 4F		所有		所有
管-坡口焊缝	1G	F	F, H	F	F, H
	2G	F, H	F, H	F, H	F, H
	5G	F, V, OH	F, V, OH	F, V, OH	F, V, OH
	6G	注 c	注 c	注 c	注 c
	2G 和 5G	注 c	注 c	注 c	注 c
	6GR	所有	所有	所有	所有
管-角焊缝	1F		F		F
	2F		F, H		F, H
	2F 转动		F, H		F, H
	4F		F, H, OH		F, H, OH
	4F 和 5F		所有		所有

^a 在评定的焊接位置范围内，焊工可以焊接带垫板或背面清根的直径大于 24 in. [600 mm]的管材。

^b 不适用于部件间两面角(ψ)小于等于 60° 的角焊缝。

^c 评定了所有的焊缝类型和焊接位置，但除了 T, Y 和 K 型的坡口焊缝。

APPENDIX XII

FILLET PROCEDURE QUALIFICATION REQUIREMENTS

Test Specimen	Fillet Size	Number of Welds per Procedure	Test Specimens Required			Sizes Qualified	
			Macroetch	All-Weld-Metal Tension	Side-Bend	Plate Thickness	Fillet Size
Plate T-test	Single-pass, max. size to be used in construction	1 in each position to be used	3 faces	—	—	Unlimited	Max. tested single-pass and smaller
	Multiple-pass, min. size to be used in construction	1 in each position to be used	3 faces	—	—	Unlimited	Min. tested multiple-pass and larger

附录 XII

角焊缝工艺评定要求

试样	角焊缝尺寸	工艺要求的焊缝数量	所需试样			评定的尺寸	
			宏观浸蚀	全焊缝金属拉伸	侧弯	板厚	角焊缝尺寸
板材	单道焊，制造中使用的最大尺寸	每个位置 1 个	3 面	—	—	无限制	不超过试验的最大单道焊
T 型试验	多道焊，制造中使用的最小尺寸	每个位置 1 个	3 面	—	—	无限制	不小于试验的最小多道焊

APPENDIX XIII

GROOVE PROCEDURE QUALIFICATION REQUIREMENTS

1. Tests on plate							
Plate Thickness (T) Tested, in	Number of Sample Welds per Position	NDT ^a	Test Specimens Required				Nominal Plate Thickness Qualified, T in ^b
			Reduced-Section Tension	Root-Bend	Face-Bend	Side-Bend	
$1/8 \leq T < 3/8$	1	Yes	2	2	2	—	1/8 to 2T
3/8	1	Yes	2	2	2	—	1/8 to 3/4
$3/8 < T < 1$	1	Yes	2	—	—	4	1/8 to 2T
1 and over	1	Yes	2	—	—	4	Unlimited

^aA minimum of 6 in of effective weld length shall be tested by radiographic or ultrasonic testing prior to mechanical testing.

^bFor square groove welds, the maximum thickness qualified shall be limited to thickness tested.

Note: All welded test plates shall be visually inspected.

2. Tests on pipe or tubing										
Pipe Size of Sample Weld		Number of Sample Welds per Position	NDT ^a	Test Specimens Required				Diameter Qualified, in	Thickness Qualified, in	
Diam.	Wall Thickness, T			Reduced-Section Tension	Root-Bend	Face-Bend	Side-Bend		Min.	Max.
2 in or 3 in	Sch. 80 Sch. 40	2	Yes	2	2	2	—	3/4 through 4	1/8	3/4
6 in or 8 in	Sch. 120 Sch. 80	1	Yes	2	—	—	4	4 and over	3/16	Unlimited
Job Size Pipe or Tubing										
Diam.	Wall Thickness, T									
< 24 in	$1/8 \leq T \leq 3/8$ in	1	Yes	2	2	2	—	Test diam. and over	1/8	2T
	$3/8 < T < 3/4$ in	1	Yes	2	—	—	4		T/2	2T
	$T \geq 3/4$ in	1	Yes	2	—	—	4		3/8	Unlimited
≥ 24 in	$1/8 \leq T \leq 3/8$ in	1	Yes	2	2	2	—	Test diam. and over 24 and over 24 and over	1/8	2T
	$3/8 < T < 3/4$ in	1	Yes	2	—	—	4		T/2	2T
	$T \geq 3/4$ in	1	Yes	2	—	—	4		3/8	Unlimited

^aFor pipe or tubing, the full circumference of the completed weld shall be tested by RT or UT prior to mechanical testing.

Note: All welded test pipes shall be visually inspected.

附录 XIII

坡口焊工艺评定要求

1. 板材试验							
试板厚度(T) in.	每个位置的 试板数量	NDT ^a	所需试样				板材公称厚度的 评定范围, T in. ^b
			缩截面拉伸	背弯	面弯	侧弯	
1/8≤T<3/8	1	需要	2	2	2	—	1/8 – 2T
3/8	1	需要	2	2	2	—	1/8 – 3/4
3/8<T<1	1	需要	2	—	—	4	1/8 – 2T
≥1	1	需要	2	—	—	4	≥1/8

^a 在机械性能试验前, 至少 6 英寸长的有效焊缝要进行射线或超声波探伤.

^b 对平坡口焊缝, 最大的评定厚度范围为试板厚度.

注: 所有焊接试板必须进行目视检验.

2. 管材试验										
试管尺寸		每个位 置的试 管数量	NDT ^a	所需试样				评定的直径 in.	厚度评定范围 in.	
直径	壁厚, T			缩截面 拉伸	背 弯	面 弯	侧 弯		最小	最大
2 in. 或 3 in.	Sch. 80 Sch. 40	2	需要	2	2	2	—	3/4 至 4	1/8	3/4
2 in. 或 3 in.	Sch. 120 Sch. 80	1	需要	2	—	—	4	≥4	3/16	无限制
工件管材尺寸										
直径	壁厚, T									
<24 in.	1/8≤T≤3/8 in.	1	需要	2	2	2	—	≥试管直径	1/8	2T
	3/8<T<3/4 in.	1		2	—	—	4		T/2	2T
	T≥3/4 in.	1		2	—	—	4		3/8	无限制
≥24 in.	1/8≤T≤3/8 in.	1	需要	2	2	2	—	≥试管直径 ≥24 in. ≥24 in.	1/8	2T
	3/8<T<3/4 in.	1		2	—	—	4		T/2	2T
	T≥3/4 in.	1		2	—	—	4		3/8	无限制

^a 在机械性能试验前, 要对整个环焊缝全长进行射线或超声波探伤.

注: 所有焊接试管必须进行目视检验.

APPENDIX XIV

PREQUALIFIED BASE METAL—FILLER METAL COMBINATIONS FOR MATCHING STRENGTH

G r o u p	Steel Specification Requirements					Filler Metal Requirements				
	Steel Specification ^{a,b}	Minimum Yield Point/Strength		Tensile Range		Process	AWS Electrode Specification ^c	Electrode Classification ^d		
		ksi	MPa	ksi	MPa					
I	ASTM A 36 ^d		36	250	58–80	400–550	SMAW	A5.1	E60XX, E70XX	
	ASTM A 53	A5.5	35	240	60 min.	415 min.		A5.5 ^f	E70XX-X	
	ASTM A 106	Grade B	35	240	60 min.	415 min.	SAW	A5.17	F6XX-EXXX, F6XX-ECXXX, F7XX-EXXX, F7XX-ECXXX	
	ASTM A 131	Grades A, B, CS, D, DS, E	34	235	58–71	400–490				
	ASTM A 139	Grade B	35	241	60 min.	414 min.				
	ASTM A 381	Grade Y35	35	240	60 min.	415 min.				
	ASTM A 500	Grade A	33	228	45 min.	310 min.				
		Grade B	42	290	58 min.	400 min.				
	ASTM A 501		36	250	58 min.	400 min.				
	ASTM A 516	Grade 55	30	205	55–75	380–515				
		Grade 60	32	220	60–80	415–550				
	ASTM A 524	Grade I	35	240	60–85	415–586				
		Grade II	30	205	55–80	380–550				
	ASTM A 529		42	290	60–85	415–585	GMAW	A5.18	ER70S-X, E70C-XC, E70C-XM (Electrodes with the -GS suffix are excluded)	
	ASTM A 570	Grade 30	30	205	49 min.	340 min.				
		Grade 33	33	230	52 min.	360 min.				
		Grade 36	36	250	53 min.	365 min.				
		Grade 40	40	275	55 min.	380 min.				
		Grade 45	45	310	60 min.	415 min.	FCAW	A5.20	E6XT-X, E6XT-XM, E7XT-X, E7XT-XM (Electrodes with the -2, -2M, -3, -10, -13, -14X, and -GS suffix are excluded)	
	ASTM A 573	Grade 65	35	240	65–77	450–530				
	Grade 58	32	220	58–71	400–490					
ASTM A 709	Grade 36 ^d	36	250	58–80	400–550					
API 5LX	Grade B	35	240	60	415					
	Grade X42	42	290	60	415					
ABS	Grades A, B, D, CS, DS			58–71	400–490					
	Grade E ^e			58–71	400–490					
						A5.29 ^f				E6XTX-X, E6XTX-XM, E7XTX-X, E7XTX-XM

Note: ASTM A 570 Grade 50 has been deleted from Group I and added to Group II.

(Continued)

附录 XIV

免除评定的母材-填充金属的强度匹配要求

组	钢材技术要求					填充金属要求			
	钢材规范 ^{a, b}	最小屈服点/强度		抗拉强度范围		焊接方法	AWS 焊材规范 ^c	焊材类别 ^g	
		ksi	MPa	ksi	MPa				
I	ASTM A36 ^d		36	250	58-80	400-550	SMAW	A5.1	E60XX, E70XX
	ASTM A53	A5.5	35	240	最小 60	最小 415			
	ASTM A106	B 级	35	240	最小 60	最小 415		A5.5 ^f	E70XX-X
	ASTM A131	A, B, CS, D, DS, E 级	34	235	58-71	400-490			
	ASTM A139	B 级	35	241	最小 60	最小 414			
	ASTM A381	Y35 级	35	240	最小 60	最小 415	SAW	A5.17	F6XX-EXXX, F6XX-ECXXX, F7XX-EXXX, F7XX-ECXXX
	ASTM A500	A 级	33	228	最小 45	最小 310			
		B 级	42	290	最小 58	最小 400			
	ASTM A501		36	250	最小 58	最小 400		A5.23 ^f	F7XX-EXXX-XX, F7XX-ECXXX-XX
	ASTM A516	55 级	30	205	55-75	380-515			
		60 级	32	220	60-80	415-550			
	ASTM A524	I 级	35	240	60-85	415-586			
		II 级	30	205	55-80	380-550	GMAW	A5.18	ER70S-X, E70C-XC, E70C-XM (不包括带-GS 后缀的焊丝)
	ASTM A529		42	290	60-85	415-585			
	ASTM A570	30 级	30	205	最小 49	最小 340			
		33 级	33	230	最小 52	最小 360			
		36 级	36	250	最小 53	最小 365			
		40 级	40	275	最小 55	最小 380			
		45 级	45	310	最小 60	最小 415	FCAW	A5.20	E6XT-X, E6XT-XM, E7XT-X, E7XT-XM (不包括带-2, -2M, -3, -10, -13, -14X, 和-GS 后缀的焊丝)
	ASTM A573	65 级	35	240	65-77	450-530			
		58 级	32	220	58-71	400-490			
ASTM A709	36 级 ^d	36	250	58-80	400-550				
API 5L	B 级	35	240	60	415		A5.29 ^f	E6XTX-X, E6XT-XM, E7XTX-X, E7XTX-XM	
	X42 级	42	290	60	415				
ABS	A, B, D, CS, DS 级			58-71	400-490				
	E 级 ^e			58-71	400-490				

注: ASTM A570 50 级已从组 I 中删除并加到组 II 中。

(待续)

APPENDIX XIV (Continued)

Group	Steel Specification Requirements					Filler Metal Requirements			
	Steel Specification ^{a,b}	Minimum Yield Point/Strength		Tensile Range		Process	AWS Electrode Specification ^c	Electrode Classification ^d	
		ksi	MPa	ksi	MPa				
G	ASTM A 131	Grades AH32, DH32, EH32	46	315	68–85	470–585	SMAW	A5.1	E7015, E7016, E7018, E7028
		Grades AH36, DH36, EH36	51	350	71–90	490–620		A5.5 ^f	E7015-X, E7016-X, E7018-X
P	ASTM A 441		40–50	275–345	60–70	415–485	SAW	A5.17	F7XX-EXXX, F7XX-BCXXX
	ASTM A 516	Grade 65	35	240	65–85	450–585			
II		Grade 70	38	260	70–90	485–620	GMAW	A5.23 ^f	F7XX-EXXX-XX, F7XX-BCXXX-XX
	ASTM A 537	Class 1	45–50	310–345	65–90	450–620			
II	ASTM A 570	Grade 50	50	345	65	450	FCAW	A5.18	ER70S-X, E70C-XC, E70C-XM (Electrodes with the -GS suffix are excluded)
		Grade 55	55	380	70	480			
II	ASTM A 572	Grade 42	42	290	60 min.	415 min.	A5.28 ^f	ER70S-XXX, E70C-XXX	
	ASTM A 572	Grade 50	50	345	65 min.	450 min.			
II	ASTM A 588 ^e	(4 in [100 mm] and under)	50	345	70 min.	485 min.	A5.29 ^f	E7XT-X, E7XT-XM (Electrodes with the -2, -2M, -3, -10, -13, -14, and -GS suffix are excluded)	
	ASTM A 595	Grade A	55	380	65 min.	450 min.			
II		Grades B and C	60	415	70 min.	480 min.	A5.29 ^f	E7XTX-X, E7XTX-XM	
	ASTM A 606 ^e		45–50	310–340	65 min.	450 min.			
II	ASTM A 607	Grade 45	45	310	60 min.	410 min.	A5.29 ^f	E7XTX-X, E7XTX-XM	
		Grade 50	50	345	65 min.	450 min.			
II		Grade 55	55	380	70 min.	480 min.	A5.29 ^f	E7XTX-X, E7XTX-XM	
	ASTM A 618	Grades 1b, II, III	46–50	315–345	65 min.	450 min.			
II	ASTM A 633	Grade A	42	290	63–83	430–570	A5.29 ^f	E7XTX-X, E7XTX-XM	
		Grades C, D (2-1/2 in [65 mm] and under)	50	345	70–90	485–620			
II	ASTM A 709	Grade 50	50	345	65 min.	450 min.	A5.29 ^f	E7XTX-X, E7XTX-XM	
		Grade 50W	50	345	70 min.	485 min.			
II	ASTM A 710	Grade A, Class 2 > 2 in [50 mm]	55	380	65 min.	450 min.	A5.29 ^f	E7XTX-X, E7XTX-XM	
	ASTM A 808	(2-1/2 in [65 mm] and under)	42	290	60 min.	415 min.			
II	ASTM A 913	Grade 50	50	345	65 min.	450 min.	A5.29 ^f	E7XTX-X, E7XTX-XM	
	ASTM A 992		50–65	345–450	65	450			
II	API 2H	Grade 42	42	290	62–80	430–550	A5.29 ^f	E7XTX-X, E7XTX-XM	
		Grade 50	50	345	70 min.	485 min.			
II	API 2W	Grade 42	42–67	290–462	62 min.	427 min.	A5.29 ^f	E7XTX-X, E7XTX-XM	
		Grade 50	50–75	345–517	65 min.	448 min.			
II		Grade 50T	50–80	345–552	70 min.	483 min.	A5.29 ^f	E7XTX-X, E7XTX-XM	
	API 2Y	Grade 42	42–67	290–462	62 min.	427 min.			
II		Grade 50	50–75	345–517	65 min.	448 min.	A5.29 ^f	E7XTX-X, E7XTX-XM	
		Grade 50T	50–80	345–552	70 min.	483 min.			
II	API 5LX	Grade X52	52	360	66–72	455–495	A5.29 ^f	E7XTX-X, E7XTX-XM	
	ABS	Grades AH32, DH32, EH32	45.5	315	71–90	490–620			
		Grades AH36, DH36, EH36 ^e	51	350	71–90	490–620			

(Continued)

附录 XIV (续)

组	钢材技术要求					填充金属要求			
	钢材规范 ^{a, b}	最小屈服点/强度		抗拉强度范围		焊接方法	AWS 焊材规范 ^c	焊材类别 ^g	
		ksi	MPa	ksi	MPa				
II	ASTM A131	AH32, DH32, EH32 级	46	315	68-85	470-585	SMAW	A5.1	E7015, E7016, E7018, E7028
		AH36, DH36, EH36 级	51	350	71-90	490-620			
	ASTM A441		40-50	275-345	60-70	415-485		A5.5 ^f	E7015-X, E7016-X, E7018-X
	ASTM A516	65 级	35	240	65-85	450-585	SAW	A5.17	F7XX-EXXX, F7XX-ECXXX
		70 级	38	260	70-90	485-620			
	ASTM A537	1 类	45-50	310-345	65-90	450-620			
	ASTM A570	50 级	50	345	65	450			
		55 级	55	380	70	480		A5.23 ^f	F7XX-EXXX-XX F7XX-ECXXX-XX
	ASTM A572	42 级	42	290	最小 60	最小 415	GMAW	A5.18	ER70S-X, E70C-XC, E70C-XM (不包括带-GS 后缀的焊丝)
	ASTM A572	50 级	50	345	最小 65	最小 450			
	ASTM A588 ^e	≤ 4in.[100mm]	50	345	最小 70	最小 485			
	ASTM A595	A 级	55	380	最小 65	最小 450			
		B 和 C 级	60	415	最小 70	最小 485			
	ASTM A606 ^e		45-50	310-340	最小 65	最小 450			
	ASTM A607	45 级	45	310	最小 60	最小 410			
		50 级	50	345	最小 65	最小 450			
		55 级	55	380	最小 70	最小 480			
	ASTM A618	Ib, II, III 级	46-50	315-345	最小 65	最小 450			
	ASTM A633	A 级	42	290	63-83	430-570			
		C, D 级	50	345	70-90	485-620		A5.29 ^f	E7XTX-X, E7XTX-XM
	ASTM A709	50 级	50	345	最小 65	最小 450			
		50W 级	50	345	最小 70	最小 485			
	ASTM A710	A 级, 2 类 >2in.[50mm]	55	380	最小 65	最小 450			
	ASTM A808	≤ 2-1/2in.[65mm]	42	290	最小 60	最小 415			
	ASTM A913	50 级	50	345	最小 65	最小 450			
	ASTM A992		50-65	345-450	65	450			
	API 2H	42 级	42	290	62-80	430-550			
		50 级	50	345	最小 70	最小 485			
	API 2W	42 级	42-67	290-462	最小 62	最小 427			
		50 级	50-75	345-517	最小 65	最小 448			
	50T 级	50-80	345-552	最小 70	最小 483				
API 2Y	42 级	42-67	290-462	最小 62	最小 427				
	50 级	50-75	345-517	最小 65	最小 448				
	50T 级	50-80	345-552	最小 70	最小 483				
API 5L	X52 级	52	360	66-72	455-495				
ABS	AH32, DH32, EH32 级	45.5	315	71-90	490-620				
	AH36, DH36, EH36 级 ^e	51	350	71-90	490-620				

(待续)

APPENDIX XIV (Continued)

G r o u p	Steel Specification Requirements						Filler Metal Requirements		
	Steel Specification ^{a,b}		Minimum Yield Point/Strength		Tensile Range		Process	AWS Electrode Specification ^c	Electrode Classification ^d
			ksi	MPa	ksi	MPa			
III	API 2W	Grade 60	60–90	414–621	75 min.	517 min.	SMAW	A5.5 ^f	E8015-X, E8016-X, E8018-X
	API 2Y	Grade 60	60–90	414–621	75 min.	517 min.	SAW	A5.23 ^f	F8XX-E3XX-XX, F8XX-EC3XX-XX
	ASTM A 572	Grade 60	60	415	75 min.	515 min.			
		Grade 65	65	450	80 min.	550 min.	GMAW	A5.28 ^f	ER80S-XXX, E80C-XXX
	ASTM A 537	Class 2 ^e	46–60	315–415	80–100	550–690			
	ASTM A 633	Grade E ^e	55–60	380–415	75–100	515–690	FCAW	A5.29 ^f	E8XTX-X, E8XTX-XM
	ASTM A 710	Grade A, Class 2 ≤ 2 in [50 mm]	60–65	415–450	72 min.	495 min.			
	ASTM A 710	Grade A, Class 3 > 2 in [50 mm]	60–65	415–450	70 min.	485 min.	SMAW	A5.5 ^f	E9015-X, E9016-X, E9018-X, E9018-M
ASTM A 913 ^h	Grade 60	60	415	75 min.	520 min.				
	Grade 65	65	450	80 min.	550 min.	SAW	A5.23 ^f	F9XX-E3XX-XX, F9XX-EC3XX-XX	
IV	ASTM A 709	Grade 70W	70	485	90–110	620–760	GMAW	A5.28 ^f	ER90S-XXX, E90C-XXX
	ASTM A 852		70	485	90–110	620–760	FCAW	A5.29 ^f	E9XTX-X, E9XTX-XM

^a In joints involving base metals of different groups, either of the following filler metals may be used: (1) that which matches the higher strength base metal, or (2) that which matches the lower strength base metal and produces a low-hydrogen deposit. Preheating shall be in conformance with the requirements applicable to the higher strength group.

^b Match API standard 2B (fabricated tubes) according to steel used.

^c When welds are to be stress-relieved, the deposited weld metal shall not exceed 0.05% vanadium.

^d Only low-hydrogen electrodes shall be used when welding ASTM A 36 or ASTM A 709 Grade 36 steel more than 1 in [25 mm] thick for cyclically loaded structures.

^e Special welding materials and WPS (e.g., E80XX-X low-alloy electrodes) may be required to match the notch toughness of base metal (for applications involving impact loading or low temperature), or for atmospheric corrosion and weathering characteristics (see 3.7.3).

^f Filler metals of alloy group B3, B3L, B4, B4L, B5, B5L, B6, B6L, B7, B7L, B8, B8L, B9, or any BXH grade in AWS A5.5, A5.23, A5.28, or A5.29 are not prequalified for use in the as-welded condition.

^g AWS A5M (SI Units) electrodes of the same classification may be used in lieu of the AWS A5 (U.S. Customary Units) electrode classification.

^h The heat input limitations of 5.7 shall not apply to ASTM A 913 Grade 60 or 65.

附录 XIV (续)

组	钢材技术要求						填充金属要求		
	钢材规范 ^{a, b}		最小屈服点/强度		抗拉强度范围		焊接方法	AWS 焊材规范 ^c	焊材类别 ^g
			ksi	MPa	ksi	MPa			
III	API 2W	60 级	60-90	414-621	最小 75	最小 517	SMAW	A5.5 ^f	E8015-X, E8016-X, E8018-X
	API 2Y	60 级	60-90	414-621	最小 75	最小 517			
	ASTM A572	60 级	60	415	最小 75	最小 515	SAW	A5.23 ^f	F8XX-EXXX-XX, F8XX-ECXXX-XX
		65 级	65	450	最小 80	最小 550			
	ASTM A537	2 类 ^e	46-60	315-415	80-100	550-690	GMAW	A5.28 ^f	ER80S-XXX, E80C-XXX
	ASTM A633	E 级 ^e	55-60	380-415	75-100	515-690			
	ASTM A710	A 级, 2 类 ≤2in. [50mm]	60-65	415-450	最小 72	最小 495	FCAW	A5.29 ^f	E8XTX-X, E8XTX-XM
	ASTM A710	A 级, 3 类 >2in. [50mm]	60-65	415-450	最小 70	最小 485			
	ASTM A913 ^h	60 级	60	415	最小 75	最小 520			
65 级		65	450	最小 80	最小 550				
IV	ASTM A709	70W 级	70	485	90-110	620-760	SMAW	A5.5 ^f	E9015-X, E9016-X, E9018-X, E9018-M
	ASTM A852		70	485	90-110	620-760	SAW	A5.23 ^f	F9XX-EXXX-XX, F9XX-ECXXX-XX
							GMAW	A5.28 ^f	ER90S-XXX, E90C-XXX
							FCAW	A5.29 ^f	E9XTX-X, E9XTX-XM

^a 当涉及不同组别母材的接头时, 可选用下列填充金属中的一种: (1) 与较高强度的母材匹配, 或 (2) 与低强度的母材匹配并且采用低氢熔敷方法. 预热必须按照较高强度组别钢材的要求.

^b 根据所用钢材, 匹配 API 标准 2B(加工的管材).

^c 当焊缝需要进行消除应力处理时, 焊缝熔敷金属的钒含量不能超过 0.05%.

^d 当焊接厚度大于 1in. [25 mm]并且用于周期载荷结构的 ASTM A36 或 ASTM A709 36 级钢材时, 只能采用低氢焊条.

^e 当有冲击或低温要求时为了满足母材的缺口韧性, 或为了达到耐大气腐蚀和风化的要求, 可能要采用特殊的焊接材料和 WPS(如 E80XX-X 低合金焊条). (见 3.7.3)

^f 在焊态下, AWS A5.5, A5.23, A5.28, or A5.29 中的 B3, B3L, B4, B4L, B5, B5L, B6, B6L, B7, B7L, B8, B8L, B9, 或任何 BXH 级合金组的填充金属是不能免除评定的.

^g 相同级别的 AWS A5M(国际单位)焊接材料可以替代 AWS A5(美国惯用单位)的焊接材料.

^h 5.7 条规定的热输入限制不适用于 ASTM A913 60 或 65 级钢材.

APPENDIX XV

MINIMUM PREHEAT AND INTERPASS TEMPERATURE^{c, d}

C a t e g o r y	Steel Specification			Welding Process	Thickness of Thickest Part at Point of Welding		Minimum Preheat and Interpass Temperature			
					in	mm	°F	°C		
A	ASTM A 36 ^b		ASTM A 516	Grades 55 & 60	Shielded metal arc welding with other than low-hydrogen electrodes	Up to 3/4 incl.	Up to 19 incl.	None ^a		
	ASTM A 53	Grade B	ASTM A 524	Grades I & II		Over 3/4	Over 19	150	66	
	ASTM A 106	Grade B	ASTM A 529			thru 1-1/2 incl.	thru 38 incl.			
	ASTM A 131	Grades A, B, CS, D, DS, E	ASTM A 570	All grades		Over 1-1/2	Over 38	225	107	
	ASTM A 139	Grade B	ASTM A 573	Grade 65		thru 2-1/2 incl.	thru 64 incl.			
	ASTM A 381	Grade Y35	ASTM A 709	Grade 36 ²						
	ASTM A 500	Grade A	API 5L	Grade B						
ASTM A 501	Grade B	API 5LX	Grade X42			300	150			
B	ASTM A 36 ^b		ASTM A 570	All grades	Shielded metal arc welding with low-hydrogen electrodes, submerged arc welding, ^b gas metal arc welding, flux cored arc welding	Up to 3/4 incl.	Up to 19 incl.	None ^a		
	ASTM A 53	Grade B	ASTM A 572	Grades 42, 50						
	ASTM A 106	Grade B	ASTM A 573	Grade 65						
	ASTM A 131	Grades A, B, CS, D, DS, E	ASTM A 588							
		AH 32 & 36	ASTM A 595	Grades A, B, C						
		DH 32 & 36	ASTM A 606							
		EH 32 & 36	ASTM A 607	Grades 45, 50, 55						
	ASTM A 139	Grade B	ASTM A 618							
	ASTM A 242		ASTM A 633	Grades A, B						
	ASTM A 381	Grade Y35	ASTM A 709	Grades C, D			Over 3/4	Over 19	50	10
	ASTM A 441		API 5L	Grades 36, 50, 50W		thru 1-1/2 incl.	thru 38 incl.			
	ASTM A 500	Grade A	API 5LX	Grade B						
	ASTM A 501	Grade B	API Spec. 2H	Grade X42						
ASTM A 516	Grades 55, 60, 65, & 70	ABS	Grades AH 32 & 36		Over 1-1/2	Over 38	150	66		
ASTM A 524	Grades I & II		DH 32 & 36	thru 2-1/2 incl.	thru 64 incl.					
ASTM A 529			EH 32 & 36							
ASTM A 537	Classes 1 & 2	ABS	Grades A, B, D, CS, DS		Over 2-1/2	Over 64	225	107		
			Grade E							

(Continued)

附录 XV
最低预热和层间温度^{c, d}

类别	钢材规范		焊接方法	焊接处最厚工件的厚度		最低预热和层间温度		
				in.	mm	^o F	^o C	
A	ASTM A36 ^b		ASTM A516	55 和 60 级	非低氢焊条手工电弧焊	≤3/4	≤19	不需要 ^a
	ASTM A53	B 级	ASTM A524	I 和 II 级				
	ASTM A106	B 级	ASTM A529					
	ASTM A131	A, B 级	ASTM A570	所有级别				
		CS, D, DS, E 级	ASTM A573	65 级				
	ASTM A139	B 级	ASTM A709	36 级 ^b				
	ASTM A381	Y35 级	API 5L	B 级				
ASTM A500	A 级	API 5LX	X42 级	>2-1/2	>64	300	150	
ASTM A501	B 级	ABS	A, B, D, CS, DS 级					
	ASTM A501		E 级					
B	ASTM A36 ^b		ASTM A570	所有级别	低氢焊条手工电弧焊 埋弧焊 ^b 熔化极气体保护焊 药芯焊丝电弧焊	≤3/4	≤19	不需要 ^a
	ASTM A53	B 级	ASTM A572	42, 50 级				
	ASTM A106	B 级	ASTM A573	65 级				
	ASTM A131	A, B 级	ASTM A588					
		CS, D, DS, E 级	ASTM A595	A, B, C 级				
		AH32 和 36 级	ASTM A606					
		DH32 和 36 级	ASTM A607	45, 50, 55 级				
		EH32 和 36 级	ASTM A618					
	ASTM A139	B 级	ASTM A633	A, B 级				
	ASTM A242			C, D 级				
	ASTM A381	Y35 级	ASTM A709	36, 50, 50W 级				
	ASTM A441		API 5L	B 级				
	ASTM A500	A 级	API 5LX	X42 级				
	B 级	API 标准 2H						
ASTM A501		ABS	AH32 和 36 级					
ASTM A516	55 和 66 级		DH32 和 36 级					
	65 和 70 级		EH32 和 36 级					
ASTM A524	I 和 II 级	ABS	A, B, D 级					
ASTM A529			CS, DS 级					
ASTM A537	1 和 2 类		E 级					
				>2-1/2	>64	225	107	

(待续)

APPENDIX XV (Continued)

C a t e g o r y	Steel Specification	Welding Process	Thickness of Thickest Part at Point of Welding		Minimum Preheat and Interpass Temperature	
			in	mm	°F	°C
C	ASTM A 572 Grades 60, 65 ASTM A 633 Grade E API 5LX Grade X52	Shielded metal arc welding with low hydrogen electrodes, submerged arc welding, gas metal arc welding, or flux cored arc welding	Up to 3/4 incl.	Up to 19 incl.	50	10
			Over 3/4 thru 1-1/2 incl.	Over 19 thru 38 incl.	150	66
			Over 1-1/2 thru 2-1/2 incl.	Over 38 thru 64 incl.	225	107
			Over 2-1/2	Over 64	300	150
D	ASTM A 514 ASTM A 517 Grades 100 & 100W ASTM A 709	Shielded metal arc welding with low hydrogen electrodes, submerged arc welding with carbon or alloy steel wire, neutral flux, gas metal arc welding, flux cored arc welding	Up to 3/4 incl.	Up to 19 incl.	50	10
			Over 3/4 thru 1-1/2 incl.	Over 19 thru 38 incl.	125	50
			Over 1-1/2 thru 2-1/2 incl.	Over 3 thru 64 incl.	175	80
			Over 2-1/2	Over 64	225	107

^a When the base metal temperature is below 32°F [0°C], the base metal shall be preheated to at least 70°F [20°C] and this minimum temperature maintained during welding.

^b Only low hydrogen electrodes shall be used when welding A 36 or A 709 Grade 36 steel more than 1 in [25 mm] thick for bridges.

^c Welding shall not be done when the ambient temperature is lower than 0°F [-18°C]. A temperature of 0°F [-18°C] does not mean the ambient environmental temperature but the temperature in the immediate vicinity of the weld. The ambient environmental temperature may be below 0°F [-18°C], but a heated structure or shelter around the area being welded could maintain the temperature adjacent to the weldment at 0°F [-18°C] or higher.

When the base metal is below the temperature listed for the welding process being used and the thickness of material being welded, it shall be preheated (except as otherwise provided) in such manner that the surfaces of the parts on which weld metal is being deposited are at or above the specified minimum temperature for a distance equal to the thickness of the part being welded, but not less than 3 in [76 mm] in all directions from the point of welding.

Preheat and interpass temperatures must be sufficient to prevent crack formation. Temperature above the minimum shown may be required for highly restrained welds. For ASTM A 514, A 517, and A 709 Grades 100 and 100W steel, the maximum preheat and interpass temperature shall not exceed 400°F [205°C] for thickness up to 1-1/2 in [38 mm] inclusive, and 450°F [230°C] for greater thickness. Heat input when welding ASTM A 514, A 517, and A 709 Grades 100 and 100W steel shall not exceed the steel producer's recommendations. ASTM A 514 and A 517 materials are not recommended to be post weld heat treated.

^d In joints involving combinations of base metals, preheat shall be as specified for the higher strength steel being welded.

附录 XV (续)

类别	钢材规范	焊接方法	焊接处最厚工件的厚度		最低预热和层间温度		
			in.	mm	°F	°C	
C	ASTM A572 ASTM A633 API 5LX	60, 65 级 E 级 X52 级	低氢焊条手工电弧焊 埋弧焊 熔化极气体保护焊 或, 药芯焊丝电弧焊	≤3/4	≤19	50	10
				>3/4, 至≤1-1/2	>19, 至≤38	150	66
				>1-1/2, 至≤2-1/2	>38, 至≤64	225	107
				>2-1/2	>64	300	150
D	ASTM A514 ASTM A517 ASTM A709	100 和 100W 级	低氢焊条手工电弧焊 碳钢或低合金钢焊丝, 中性焊剂埋弧焊 熔化极气体保护焊 药芯焊丝电弧焊	≤3/4	≤19	50	10
				>3/4, 至≤1-1/2	>19, 至≤38	125	50
				>1-1/2, 至≤2-1/2	>38, 至≤64	175	80
				>2-1/2	>64	225	107

^a 当母材温度低于 32°F[0°C]时, 母材必须至少预热到 70°F[20°C], 并且这个最低温度在焊接时也必须要保持。

^b 当厚度超过 1in. [25 mm]的 ASTM A36 和 ASTM A709 36 级的钢材用于桥梁焊接时, 只能采用低氢焊条。

^c 当周围温度低于 0°F[-18°C]时, 焊接不能进行。温度 0°F[-18°C]不是指周围环境温度, 而是指邻近焊缝区域的温度。周围环境温度可能低于 0°F[-18°C], 但围绕被焊区域的加热装置或屏蔽物能够使得邻近焊接件处的温度保持在 0°F[-18°C]或更高。

当母材温度低于所采用的焊接方法和被焊材料厚度要求的温度时, 母材必须按如下方式预热(除非另有措施): 在焊接点所有方向上等于焊件厚度且不小于 3in. [75 mm]的范围内应等于或高于要求的最低温度。

预热和层间温度必须足够以防止裂纹的产生。对于受到较高拘束度的焊缝可能需要比上表所示最低温度高的温度。对于 ASTM A514, A517 及 A709 100 和 100W 级的钢材, 当厚度≤1-1/2 in. [38 mm]时, 最高预热和层间温度不能超过 400°F[205°C], 当厚度>1-1/2 in. [38 mm]时, 最高预热和层间温度不能超过 450°F[230°C]。当焊接 ASTM A514, A517 及 A709 100 和 100W 级的钢材时, 热输入不能超过钢材制造商的推荐值。ASTM A514 和 A517 材料不推荐做焊后热处理。

^d 对于涉及不同组别母材的接头时, 预热必须按照所焊的较高强度钢材的规定进行。

APPENDIX XVI RADIOGRAPHIC TESTING

1. Welding Procedure Qualification

- 1.1 After meeting visual inspection acceptance criteria and before preparing mechanical test specimens, the procedure qualification test specimens, the qualification test plate, pipe, or tubing shall be nondestructively tested for soundness.
- 1.2 Either radiographic or ultrasonic testing shall be used. The entire length of the weld in the test plates, except the discard lengths at each end, shall be examined.
- 1.3 For acceptable qualification, the weld, as revealed by radiographic or ultrasonic testing, shall conform to the requirements of paragraph 3.

2. Welder Performance Qualification

- 2.1 Except for joints welded by GMAW-S, radiographic examination of a welder or welding operator qualification test plate or test pipe may be made in lieu of guided bend tests.
 - 2.1.1 If RT is used in lieu of the prescribed bend tests, the weld reinforcement need not be ground or otherwise smoothed for inspection unless its surface irregularities or juncture with the base metal would cause objectionable weld discontinuities to be obscured in the radiograph. If the backing is removed for radiography, the root shall be ground flush with the base metal.
 - 2.1.2 For welder qualification, exclude 1-1/4 in [32 mm] at each end of the weld from evaluation in the plate test; for welding operator qualification exclude 3 in [75 mm] at each end of the test plate length. Welded test pipe or tubing 4 in [100 mm] in diameter or larger shall be examined for a minimum of one-half of the weld perimeter selected to include a sample of all positions welded.
 - 2.1.3 For acceptable qualification, the weld, as revealed by the radiograph, shall conform to the requirements of 3.1.

3. Radiographic Inspection

Discontinuities other than cracks shall be evaluated on the basis of being either elongated or rounded. Regardless of the type of discontinuity, an elongated discontinuity is one in which its length exceeds three times its width. A rounded discontinuity is one in which its length is three times its width or less and may be round or irregular and may have tails.

3.1 Acceptance Criteria for Cyclically Loaded Nontubular Connections. Welds that are subject to radiographic testing in addition to visual inspection shall have no cracks and shall be unacceptable if the radiographic testing shows any of the types of discontinuities listed in 3.1.1 and 3.1.2.

- 3.1.1 For welds subjected to tensile stress under any condition of loading, the greatest dimension of any porosity or fusion-type discontinuity that is 1/16 in [2 mm] or larger in greatest dimension shall not exceed the size B indicated in Figure 6.4 for the weld size involved. The distance from any porosity or fusion-type discontinuity described above to another such discontinuity, to an edge, or to the toe or root of any intersecting flange-to-web weld shall be not less than the minimum clearance allowed, C, indicated in Figure 6.4 (see page 3-49), for the size of discontinuity under examination.
- 3.1.2 Independent of the requirements of 3.1.1, discontinuities having a greatest dimension of less than 1/16 in [2 mm] shall be unacceptable if the sum of their greatest dimensions exceeds 3/8 in [10 mm] in any linear inch [25.4 mm] of weld.

附录 XVI

射线探伤

1. 焊接工艺评定

- 1.1 在目视检验合格后但在机械性能试样加工之前, 工艺评定试验的试板或试管必须要进行无损探伤以确定完好性.
- 1.2 必须要采用射线或超声波探伤. 除试板两端的舍弃长度外, 试板的焊缝全长必须都要检测.
- 1.3 对于合格的评定, 经射线或超声波探伤的焊缝必须符合第 3 节的要求.

2. 焊工技能评定

- 2.1 除了采用短路过渡的熔化极气体保护焊(GMAW-S)焊接的接头外, 用以评定焊工或焊接操作工的试板或试管, 可以采用射线检测替代导向弯曲试验.
 - 2.1.1 如果用 RT 替代规定的导向弯曲试验, 焊缝余高不需要打磨或用其他方式加工平滑, 除非焊缝表面的不规则或焊缝和母材的结合区域在射线底片上使焊缝中有疑问的不连续被遮盖. 如果为射线探伤而去除了衬垫, 则焊缝根部必须打磨至与母材平齐.
 - 2.1.2 对焊工的评定, 试板两端焊缝各 1-1/4 in. [32 mm]长不作评定; 对焊接操作工的评定, 试板两端焊缝各 3 in. [75 mm]长不作评定. 直径大于等于 4 in [100 mm]的试管必须至少应检测包括所有焊接位置的焊缝周长的一半.
 - 2.1.3 对于合格的评定, 经射线探伤的焊缝必须符合第 3.1 节的要求.

3. 射线检查

除裂纹外的不连续必须按条状或圆形来评定. 不用考虑不连续的类型, 长度超过宽度三倍的不连续是条状不连续. 长度小于等于宽度三倍的不连续是圆形不连续, 它可以是圆的, 不规则的或带有尾巴.

- 3.1 **承受周期载荷的非管材连接的验收准则.** 目视检验后需要射线探伤的焊缝不允许有裂纹. 如果射线探伤发现任何类型的列于 3.1.1 和 3.1.2 的不连续, 则该焊缝是不合格的.
 - 3.1.1 在任何载荷条件下, 对于承受拉应力的焊缝, 任何最大尺寸大于等于 1/16 in [2 mm]的气孔或熔合型不连续的最大尺寸不得超过按焊缝尺寸在图 6.4 中所示的尺寸 B. 上述任何气孔或熔合型不连续与另一个这样的不连续, 或与端部, 或与翼板和腹板焊缝的焊趾或焊根的距离不得小于图 6.4(见 3-49 页)中的对所检不连续尺寸可允许的最小间距 C.
 - 3.1.2 除了 3.1.1 的要求外, 如果在任何 1 inch [25.4 mm]长的焊缝范围内, 最大尺寸小于 1/16 in [2 mm]的不连续的最大尺寸总和超过 3/8 in [10 mm], 则该不连续是不合格的.

APPENDIX XVI (Continued)

HOLE-TYPE IMAGE QUALITY INDICATOR (IQI) REQUIREMENTS

Nominal Material Thickness ^a Range, in	Nominal Material Thickness ^a Range, mm	Source Side		Film Side ^b	
		Designation	Essential Hole	Designation	Essential Hole
Up to 0.25 incl.	Up to 6 incl.	10	4T	7	4T
Over 0.25 to 0.375	Over 6 through 10	12	4T	10	4T
Over 0.375 to 0.50	Over 10 through 12	15	4T	12	4T
Over 0.50 to 0.625	Over 12 through 16	15	4T	12	4T
Over 0.625 to 0.75	Over 16 through 20	17	4T	15	4T
Over 0.75 to 0.875	Over 20 through 22	20	4T	17	4T
Over 0.875 to 1.00	Over 22 through 25	20	4T	17	4T
Over 1.00 to 1.25	Over 25 through 32	25	4T	20	4T
Over 1.25 to 1.50	Over 32 through 38	30	2T	25	2T
Over 1.50 to 2.00	Over 38 through 50	35	2T	30	2T
Over 2.00 to 2.50	Over 50 through 65	40	2T	35	2T
Over 2.50 to 3.00	Over 65 through 75	45	2T	40	2T
Over 3.00 to 4.00	Over 75 through 100	50	2T	45	2T
Over 4.00 to 6.00	Over 100 through 150	60	2T	50	2T
Over 6.00 to 8.00	Over 150 through 200	80	2T	60	2T

^a Single-wall radiographic thickness (for tubulars).

^b Applicable to tubular structures only.

WIRE IMAGE QUALITY INDICATOR (IQI) REQUIREMENTS

Nominal Material Thickness ^a Range, in	Nominal Material Thickness ^a Range, mm	Source Side		Film Side ^b	
		Maximum Wire Diameter		Maximum Wire Diameter	
		in	mm	in	mm
Up to 0.25 incl.	Up to 6 incl.	0.010	0.25	0.008	0.20
Over 0.25 to 0.375	Over 6 to 10	0.013	0.33	0.010	0.25
Over 0.375 to 0.625	Over 10 to 16	0.016	0.41	0.013	0.33
Over 0.625 to 0.75	Over 16 to 20	0.020	0.51	0.016	0.41
Over 0.75 to 1.50	Over 20 to 38	0.025	0.63	0.020	0.51
Over 1.50 to 2.00	Over 38 to 50	0.032	0.81	0.025	0.63
Over 2.00 to 2.50	Over 50 to 65	0.040	1.02	0.032	0.81
Over 2.50 to 4.00	Over 65 to 100	0.050	1.27	0.040	1.02
Over 4.00 to 6.00	Over 100 to 150	0.063	1.60	0.050	1.27
Over 6.00 to 8.00	Over 150 to 200	0.100	2.54	0.063	1.60

^a Single-wall radiographic thickness (for tubulars).

^b Applicable to tubular structures only.

附录 XVI (续)

孔型像质计(IQI)的要求

材料公称厚度 ^a 范围, in.	材料公称厚度 ^a 范围, mm	射源侧		胶片侧 ^b	
		标识号	基本孔	标识号	基本孔
≤0.25	≤6	10	4T	7	4T
>0.25, 至≤0.375	>6, 至≤10	12	4T	10	4T
>0.375, 至≤0.50	>10, 至≤12	15	4T	12	4T
>0.50, 至≤0.625	>12, 至≤16	15	4T	12	4T
>0.625, 至≤0.75	>16, 至≤20	17	4T	15	4T
>0.75, 至≤0.875	>20, 至≤22	20	4T	17	4T
>0.875, 至≤1.00	>22, 至≤25	20	4T	17	4T
>1.00, 至≤1.25	>25, 至≤32	25	4T	20	4T
>1.25, 至≤1.50	>32, 至≤38	30	2T	25	2T
>1.50, 至≤2.00	>38, 至≤50	35	2T	30	2T
>2.00, 至≤2.50	>50, 至≤65	40	2T	35	2T
>2.50, 至≤3.00	>65, 至≤75	45	2T	40	2T
>3.00, 至≤4.00	>75, 至≤100	50	2T	45	2T
>4.00, 至≤6.00	>100, 至≤150	60	2T	50	2T
>6.00, 至≤8.00	>150, 至≤200	80	2T	60	2T

^a 单壁透照厚度(对管材).

^b 仅适用于管材结构.

线型像质计(IQI)的要求

材料公称厚度 ^a 范围, in.	材料公称厚度 ^a 范围, mm	射源侧最大线经		胶片侧 ^b 最大线经	
		in.	mm	in.	mm
≤0.25	≤6	0.010	0.25	0.008	0.20
>0.25, 至≤0.375	>6, 至≤10	0.013	0.33	0.010	0.25
>0.375, 至≤0.625	>10, 至≤16	0.016	0.41	0.013	0.33
>0.625, 至≤0.75	>16, 至≤20	0.020	0.51	0.016	0.41
>0.75, 至≤1.50	>20, 至≤38	0.025	0.63	0.020	0.51
>1.50, 至≤2.00	>38, 至≤50	0.032	0.81	0.025	0.63
>2.00, 至≤2.50	>50, 至≤65	0.040	1.02	0.032	0.81
>2.50, 至≤4.00	>65, 至≤100	0.050	1.27	0.040	1.02
>4.00, 至≤6.00	>100, 至≤150	0.063	1.60	0.050	1.27
>6.00, 至≤8.00	>150, 至≤200	0.100	2.54	0.063	1.60

^a 单壁透照厚度(对管材).

^b 仅适用于管材结构.

APPENDIX XVI (Continued)

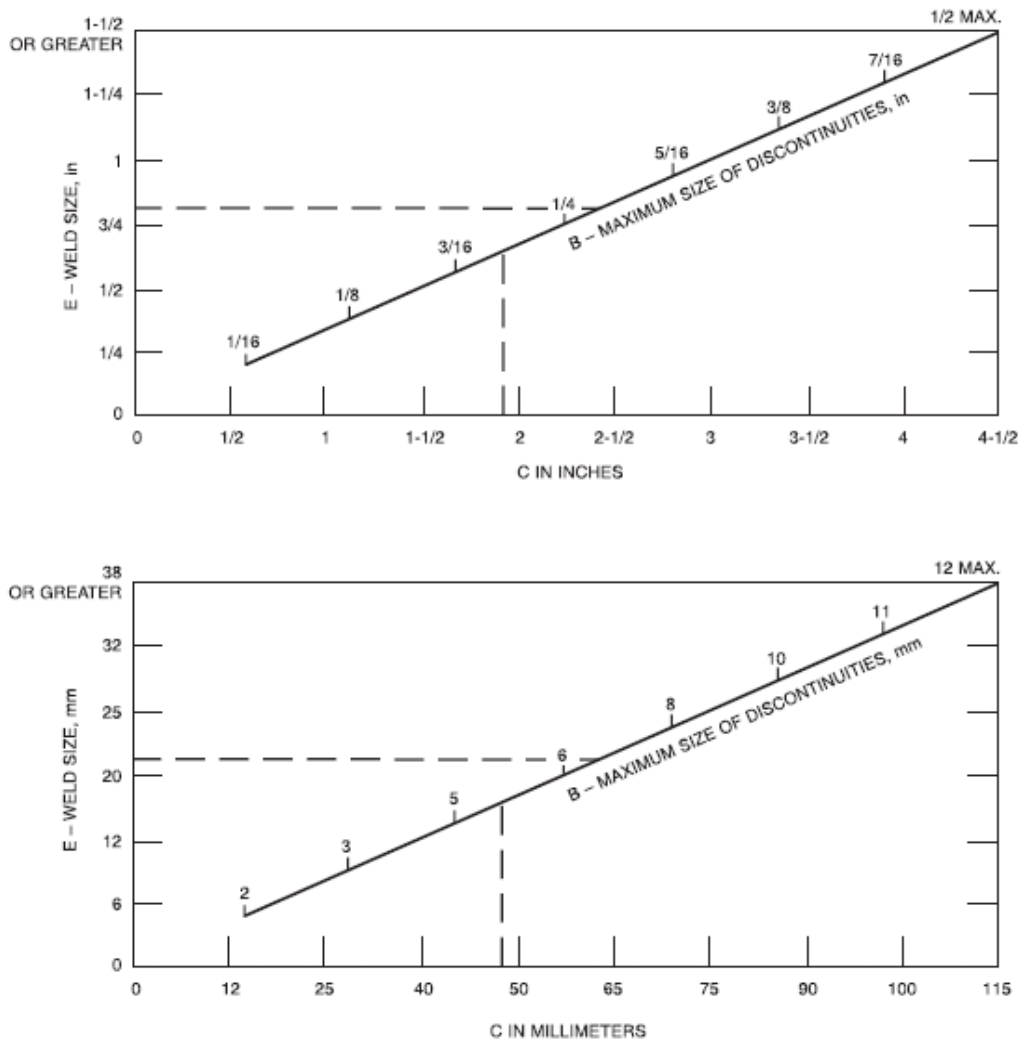

Notes:

1. To determine the maximum size of discontinuity allowed in any joint or weld size, project E horizontally to B.
2. To determine the minimum clearance allowed between edges of discontinuities of any size, project B vertically to C.
3. See Legend below for definitions.

Figure 6.4—Weld Quality Requirements for Discontinuities Occurring in Cyclically Loaded Nontubular Tension Welds (Limitations of Porosity and Fusion Discontinuities)

附录 XVI (续)

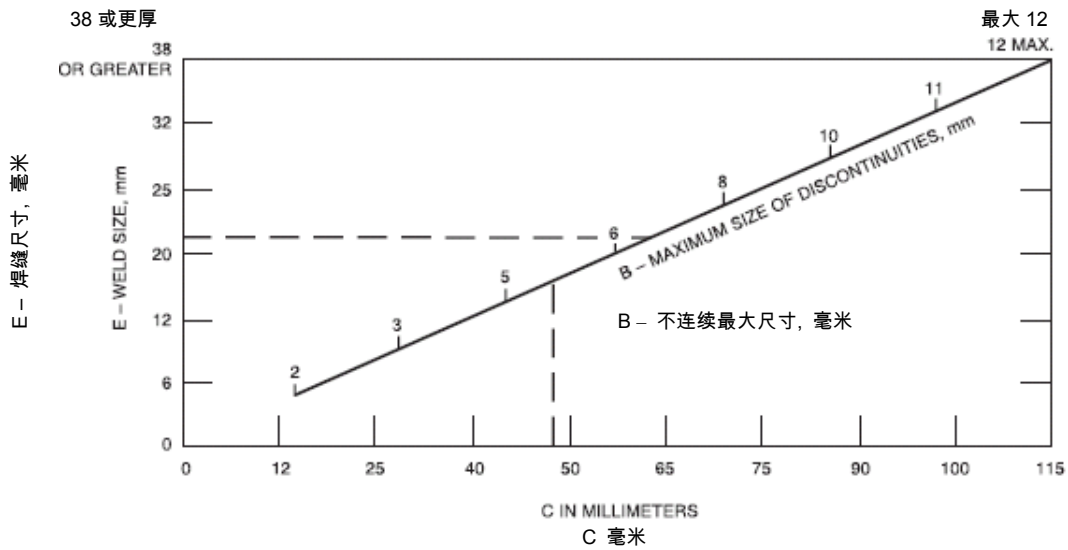
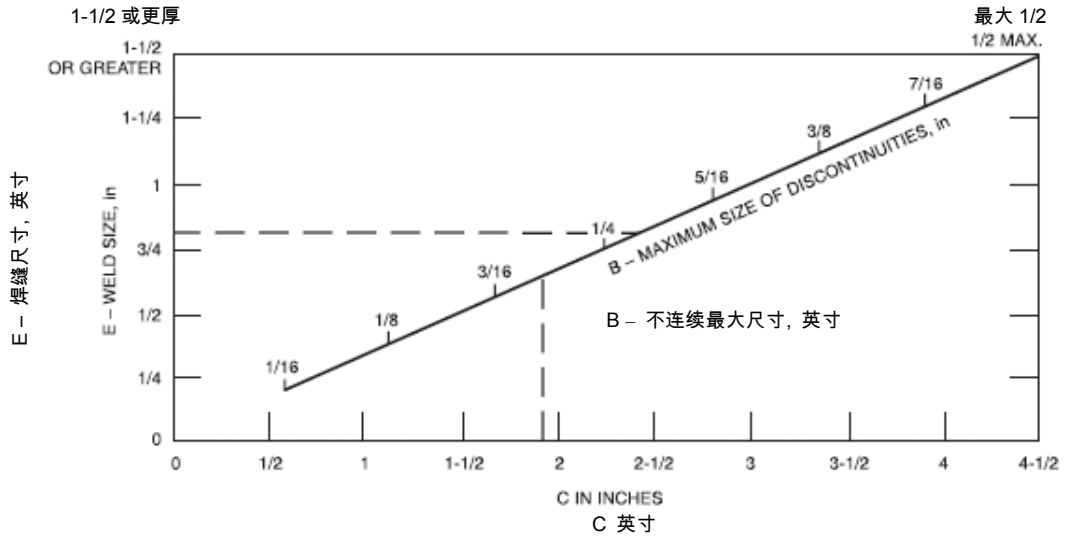

注:

1. 水平投影 E 至 B, 以确定任何接头或焊缝尺寸的允许的最大不连续尺寸.
2. 垂直投影 B 至 C, 以确定任何尺寸的两个不连续边缘之间的允许的最小间距.
3. 参见下面的符号定义说明.

图 6.4 - 非管材周期载荷拉伸焊缝的不连续的焊缝质量要求
(气孔和熔合型不连续的限制)

APPENDIX XVI (Continued)

Legend

Dimensions of Discontinuities

B = Maximum allowed dimension of a radiographed discontinuity.

L = Largest dimension of a radiographed discontinuity.

L' = Largest dimension of adjacent discontinuities.

C = Minimum clearance measured along the longitudinal axis of the weld between edges of porosity or fusion-type discontinuities (larger of adjacent discontinuities governs), or to an edge or an end of an intersecting weld.

C₁ = Minimum allowed distance between the nearest discontinuity to the free edge of a plate or tubular, or the intersection of a longitudinal weld with a girth weld, measured parallel to the longitudinal weld axis.

W = Smallest dimension of either of adjacent discontinuities.

Material Dimensions

E = Weld size.

T = Plate or pipe thickness for CJP groove welds.

Definitions of Discontinuities

- An elongated discontinuity shall have the largest dimension (L) exceed 3 times the smallest dimension.

- A rounded discontinuity shall have the largest dimension (L) less than or equal to 3 times the smallest dimension.

- A cluster shall be defined as a group of nonaligned, acceptably-sized, individual adjacent discontinuities with spacing less than the minimum allowed (C) for the largest individual adjacent discontinuity (L'), but with the sum of the greatest dimensions (L) of all discontinuities in the cluster equal to or less than the maximum allowable individual discontinuity size (B). Such clusters shall be considered as individual discontinuities of size L for the purpose of assessing minimum spacing.

- Aligned discontinuities shall have the major axes of each discontinuity approximately aligned.

附录 XVI (续)

符号说明

不连续的尺寸

B = 射线照相不连续的最大允许尺寸.

L = 射线照相不连续的最大尺寸.

L' = 相邻不连续的最大尺寸.

C = 气孔或熔合性不连续彼此边缘之间(以相邻较大不连续来确定), 或到一相交焊缝的边缘或端部的, 沿焊缝纵轴测量的最小间距.

C₁ = 从最近的不连续到板或管的自由端, 或到纵缝环缝的交叉处的, 平行于纵向焊缝轴线测量的最小允许距离.

W = 任意两个相邻不连续之间的最小尺寸.

材料尺寸

E = 焊缝尺寸

T = 全焊透(CJP)坡口焊缝的板或管材厚度

不连续的定义

- 最大尺寸(L)超过最小尺寸三倍的不连续是条状不连续.
- 最大尺寸(L)小于等于最小尺寸的三倍不连续是圆形不连续.
- 密集性不连续是指一组非线性分布的, 有可接收尺寸的, 最大的单个相邻不连续(L')与单个邻近不连续的间距小于最小间距(C), 但所有密集性不连续的最大尺寸(L)之和等于或小于单个不连续的最大允许尺寸(B). 在评定最小间距时, 这种密集性不连续应被考虑为尺寸为 L 的单个不连续.
- 线性分布的不连续是指每个不连续的主轴线近似成一直线分布.

APPENDIX XVII

FACE AND ROOT BEND SPECIMENS

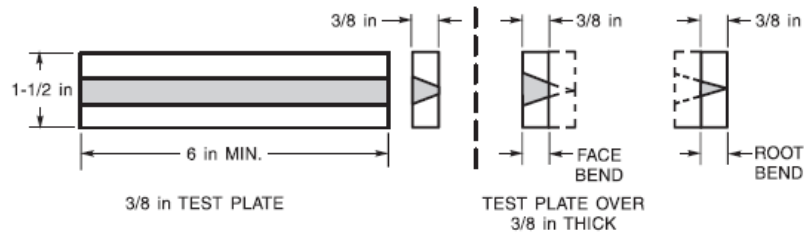

(1) LONGITUDINAL BEND SPECIMEN

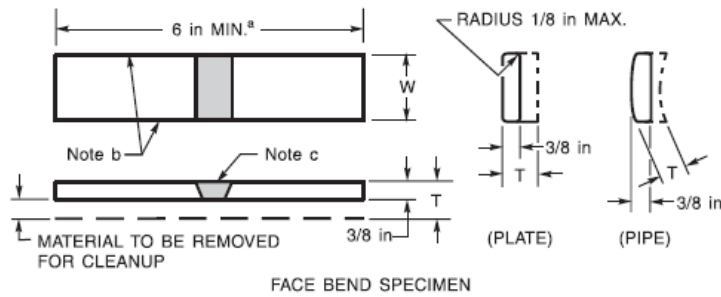

FACE BEND SPECIMEN

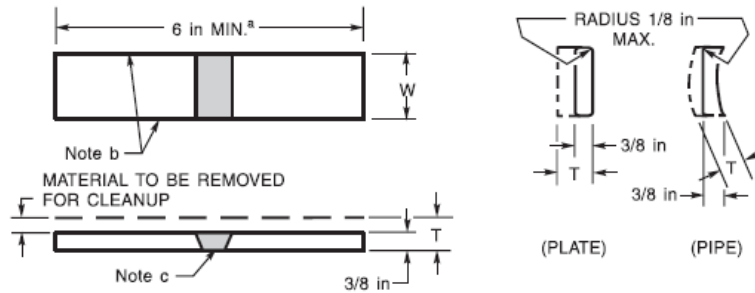

ROOT BEND SPECIMEN

(2) TRANSVERSE BEND SPECIMEN

Dimensions	
Test Weldment	Test Specimen Width, W in
Plate	1-1/2
Test pipe or tube ≤ 4 inches in diameter	1
Test pipe or tube > 4 inches in diameter	1-1/2

^aA longer specimen length may be necessary when using a wraparound type bending fixture or when testing steel with a yield strength of 90 ksi [620 MPa] or more.

^bThese edges may be thermal-cut and may or may not be machined.

^cThe weld reinforcement and backing, if any, shall be removed flush with the surface of the specimen. If a recessed backing is used, this surface may be machined to a depth not exceeding the depth of the recess to remove the backing; in such a case, the thickness of the finished specimen shall be that specified above. Cut surfaces shall be smooth and parallel.

Notes:

1. T = plate or pipe thickness.

2. When the thickness of the test plate is less than 3/8 in [10 mm], the nominal thickness shall be used for face and root bends.

附录 XVII

面弯和背弯试样

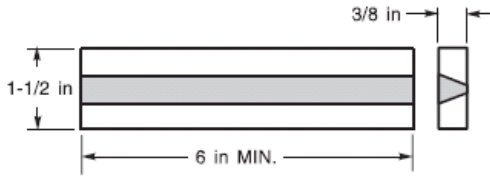

厚度为 3/8 英寸的试板

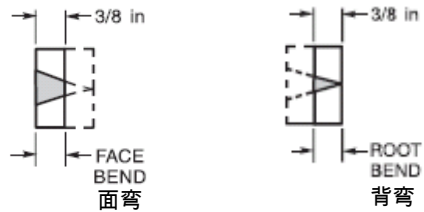

厚度为大于 3/8 英寸的试板

(1) 纵向弯曲试样

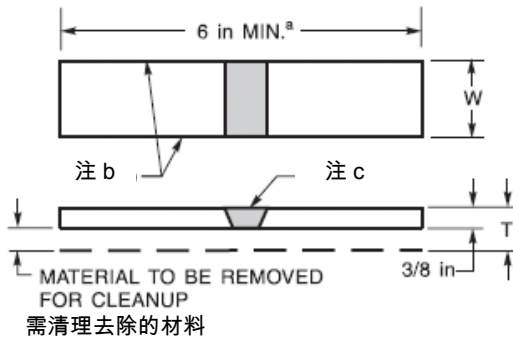

面弯试样

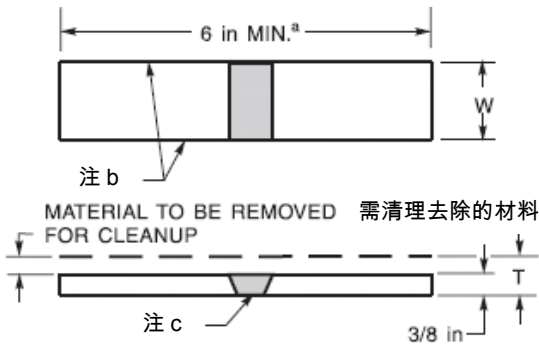
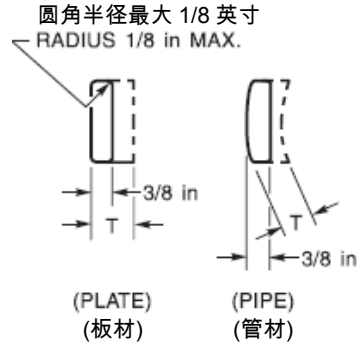

背弯试样

(2) 横向弯曲试样

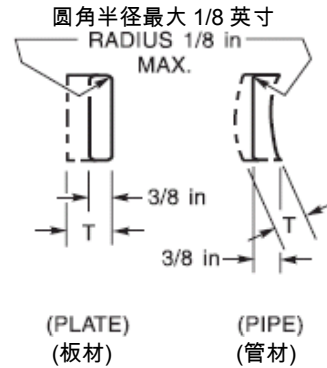

尺寸	
试验焊件	试样宽度, W, in.
板	1-1/2
试管直径 ≤ 4 in.	1
试管直径 > 4 in.	1-1/2

- ^a 当采用缠绕式弯曲装置或试验钢材的屈服强度大于等于 90 ksi [620 MPa]时, 可能需要长度更长的试样.
- ^b 这些边缘可以热切割, 并且可以机加工, 也可以不进行机加工.
- ^c 焊缝的余高和衬垫(如果有衬垫)必须去除至与试样表面齐平. 如果使用的是凹陷型衬垫, 则去除衬垫时, 试样表面可以机加工至不超过衬垫凹陷的深度; 在这种情况下, 最终试样的厚度必须是上面规定的厚度. 切割表面必须光滑并且平行.

注:

1. T = 板材或管材的厚度
2. 当试板厚度小于 3/8 in. [10 mm]时, 面弯和背弯应采用公称厚度.

